

High-Frequency Gravitational Wave Communications Study (GravCom®)

TSC-TR-09-1

**Robert M L Baker, Jr.
Transportation Sciences Corporation
8123 Tuscany Avenue
Playa del Rey, CA 90293**

August 2009 Revision

Special Report

© Transportation Sciences Corporation

MEDIA CONTACT:
Robin Fell, GravWave® LLC,
HFGWmedia@gmail.com

EXECUTIVE SUMMARY

- Fourteen laboratory High-Frequency Gravitational Wave (HFGW) generators (or transmitters) have been proposed in the past 45 years in peer-reviewed journal articles by the Russians, Germans, Italians and Chinese.
- The most promising laboratory HFGW generators are those that utilize very large numbers of radiation elements.
- The Piezoelectric-Crystal Approach to HFGW generation is best for the proof-of-concept test and is probably best for prototype communications HFGW transmitter.
- Ten different HFGW detectors (or receivers) have been proposed since 1978, as reported in peer-reviewed journal articles, and three of them have been actually built outside of the United States by the British, Italians and Japanese.
- Several different HFGW receivers could be utilized for communication; but the proposed Li-Baker detector shows the most promise. The Li-effect, upon which the Li-Baker detector is based, was first published in 1992. Subsequently the “Li Effect” was validated by eight journal articles; independently peer reviewed by scientists presumably well versed in general relativity.
- Because HFGW communications are carried on an extremely narrow beam directly through the Earth; there is a very low probability of intercept (LPI).
- Theoretical results confirm that the Li-Baker Detector is photon-signal limited, not quantum noise limited; i. e., the Standard Quantum Limit, due to the Heisenberg Uncertainty Principal, is so low that a properly designed Li-Baker detector can have sufficient sensitivity to observe HFGWs of amplitude $A \approx 10^{-37} m/m$ or smaller..
- Utilizing a double-helix piezoelectric-crystal HFGW generator approach and the Li-Baker detector, theoretically information can be transmitted 13,000 km, beamed directly through the Earth.
- A means of propagating a Frequency Time Standard (FTS) may be one viable early low-bandwidth applications for HFGW communications and improved geoid mapping.
- HFGW sources on Earth, on the Moon, and on Mars may act as reference standards for *interplanetary navigation*, with the advantage that they can not be shielded or shadowed by planetary masses. Plasma interference seen at planetary entry would be eliminated and precise charting of Lagrangian points made possible.
- Other very theoretical HFGW applications, to be validated by a proof-of-concept HFGW generation-detection test, include remotely HFGW-generated nuclear fusion, HFGW propulsion and displacement of space objects, such as warheads and anti-missiles, and HFGW surveillance directly through the Earth, oceans, buildings, etc..

About Transportation Sciences Corporation

Transportation Sciences Corporation, or TSC, is a company dedicated to the research, development, and manufacture of products involving the generation, detection, and application of High-Frequency Gravitational Waves (HFGWs) in the United States. It is a California Corporation founded in 1967 and based in Playa del Ray, California. It is a National Science Foundation *FastLane* participant (NSF ID 000512905, TSC ID 6250016969). Its DUNS Number is 783491590. TSC has received U S Navy contracts in the area of submarine surveillance and unmanned hydrophone-array tender design, prototype construction and test and hydrofoil sail craft design and is now involved in efforts to create important practical, commercial and military high-technology applications of HFGWs, including communication (GravCom®), propulsion, remote force generation, imaging, energy generation, radioactive-waste-free nuclear-energy generation, astronomy, and applied physics in the United States. The Corporation's mission is accomplished through rigorous research and experiments reported in peer-reviewed scientific journals. These efforts will lead to the development, manufacture, production, and sale of nano-, micro-, and macro-scale HFGW devices and equipments, many intended to improve the quality of life.

The President Dr. Robert Baker is a pioneer in HFGW research. He and Dr. Robert L. Forward lectured on HFGWs in 1961. Dr. Baker co-chaired the first HFGW Workshop at *MITRE Corporation* in 2003, which included 25 papers from 9 countries, was Honorary Chairman of the second International High-Frequency Gravitational Wave Workshop at Austin Texas in September 2007, Chairman of the third at Huntsville, Alabama in 2009 and cochairman of the HFGW Symposium at John Hopkins University Applied Physics Laboratory in 2010. He has published some 35 peer-reviewed papers on HFGW technology, and has been granted six patents on HFGW devices, including the Li-Baker HFGW Detector. Please visit DrRobertBaker@GravWave.com.

1.0 INTRODUCTION

1.1 Introduction

Of the applications of high-frequency gravitational waves (HFGWs), communication appears to be the most important and most immediate. Gravitational waves (GWs) have a very low cross section for absorption by normal matter, so high-frequency waves could, in principle, carry significant information content with effectively no absorption unlike electromagnetic (EM) waves. Although HFGWs do not interact with and are not absorbed by ordinary matter, their presence can be detected by their distortion of spacetime as measured by the low-frequency GW detectors such as the Laser Interferometer Gravitational Observatory (LIGO), Virgo, GEO600, et al., by detection photons generated from electromagnetic beams having the same frequency, direction and phase as the HFGWs in a superimposed magnetic field (Li-Baker HFGW Detector), by the change in polarization HFGWs produce in a microwave guide (Birmingham University Detector) and by other such instruments that have been constructed in Italy and Japan. Multi-channel HFGW communications can be both point-to-point (for example, to deeply submerged submarines) and point-to-multipoint, like cell phones. HFGWs pass through all ordinary material things without attenuation and represent the ultimate wireless system. One could communicate directly through the Earth from Moscow in Russia to Caracas in Venezuela—without the need for fiber optic cables, microwave relays, or satellite transponders. Antennas, cables, and phone lines would be things of the past. A timing standard alone, provided by HFGW stations around the globe, could result in a multi-billion dollar savings in conventional telecom systems over ten years, according to the recent analysis of Harper and Stephenson (2007 presented in section 3.3). The communication and navigation needs of future magneto hydrodynamic (MHD) aerospace vehicles, such as the MHD aerodyne (www.mhdprospects.com), which is high in electromagnetic interference, similar to plasma interference seen at entry, would be another possible applications area for HFGW communications.

1.2 Definition of High-Frequency Gravitational Waves (HFGWs)

Visualize the luffing of a sail as a sailboat comes about or tacks. The waves in the sail's fabric are similar in many ways to gravitational waves (GWs), but instead of sailcloth fabric, gravitational waves move through a "fabric" of space. Einstein called this fabric the "space-time continuum" in his 1915 work known as General Relativity (GR). Although his theory is very sophisticated, the concept is relatively simple. This fabric is four-dimensional: it has the three usual dimensions of space—east-west, north-south, and up-down—plus the fourth dimension of time. Here is an example: we define a location on this "fabric" (Einstein, 1916) as 5th Street and Third Avenue on the fourth floor at 9 AM. We can't see this "fabric," just as we can't see wind, sound, or gravity. Nevertheless, those elements are real, and so is this "fabric." If we could generate ripples in this space-time fabric, then many applications would become available to us. Much like radio waves can be used to transmit information through space, we could use gravitational waves to perform analogous functions. Gravitational waves are the subject of extensive current research, which so far has focused on low frequencies. High-frequency gravitational

waves, as defined by physicists Douglass and Braginsky (1979), are gravitational waves having frequencies higher than 100 kHz. Low-frequency gravitational waves (LFGWs), such as those detectable by interferometric GW detectors (e.g., LIGO, Virgo and GEO 600) are not applicable to communications due to their very long wavelengths, often thousands of kilometers in length and, even more importantly, the inability to generate them effectively in the laboratory. Furthermore LFGW detectors cannot detect HFGWs (Shawhan, 2004).

2.0 HFGW COMMUNICATIONS

Consider the case of a single point-to-point two station full duplex communication system, as is represented in Fig. 2.0. Such a system is often characterized as a single data link, and requires two transmitters, one at each end, and two receivers, one at each end. To avoid self-interference the link in one direction often uses a frequency of radiation different than the link in the opposite direction.

If one were to apply the emerging technology of gravitational wave transmission to such a link, one would use GW generators for the transmitters on each end, and GW sensors for the receivers at each end (Stephenson, 2009a). In the example shown in Fig. 2.0 station 1 would have a GW generator transmitting at a frequency of ω_1 and a GW sensor sensitive to a frequency of ω_2 , without being sensitive to a frequency of ω_1 . Likewise, station 2 would have a GW generator transmitting at a frequency of ω_2 and a GW sensor sensitive to a frequency of ω_1 , without being sensitive to a frequency of ω_2 . This is the minimum functionality required to constitute a communication link. Signal strengths of the respective GW generators would need to be sufficient to overcome link loss, coupling losses and noises sources.

Figure 2.0. Communication Link Block Diagram.

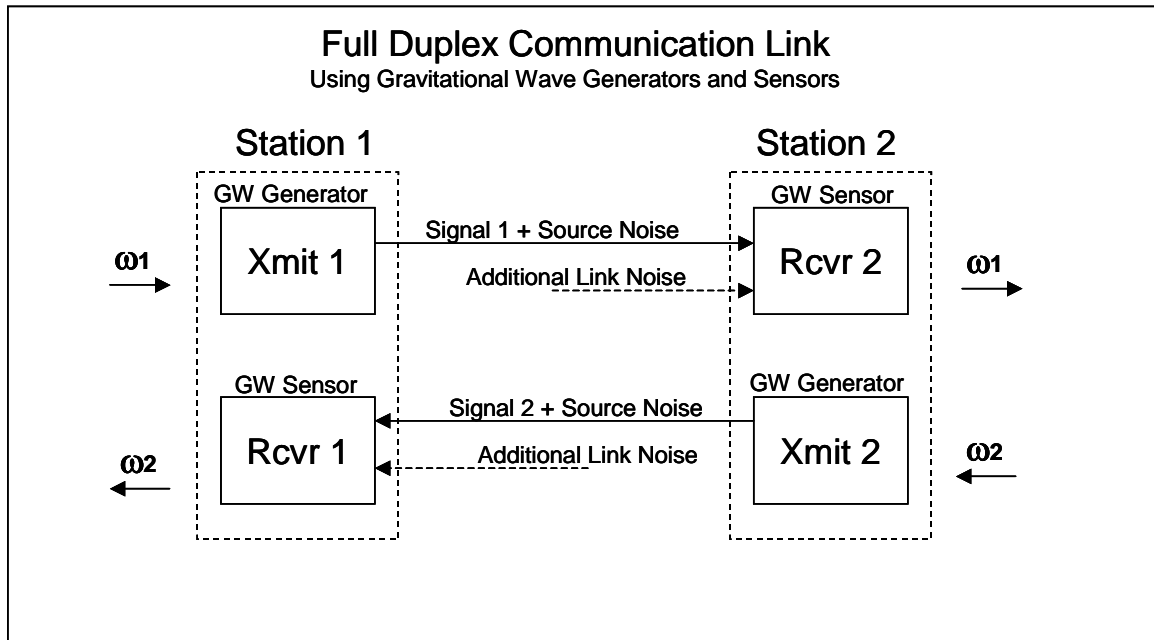

Necessary theoretical development must include electromagnetic (EM) to gravitational wave (GW) coupling for HFGW transmitters, and GW to EM response for HFGW detectors before a communication system can be designed. In the next sections, a variety of options for both GW generators and GW sensors that may ultimately be applicable to the creation of GW communication systems are reviewed.

2.1 HFGW Generators (Transmitters)

2.1.1 HFGW Generator Concepts

There exist several sources for HFGWs or means for their generation. The first generation means is the same for gravitational waves (GWs) of all frequencies and is based upon the quadrupole equation first derived by Einstein in 1918. A formulation of the quadrupole that is easily related to the orbital motion of binary stars or black holes, rotating rods, laboratory HFGW generation, etc. is based upon the jerk or shake of mass (time rate of change of acceleration), such as the change in centrifugal force vector with time; for example as masses move around each other on a circular orbit. Figure 2.1.1 describes that situation. Please recognize, however, that change in force Δf need NOT be a gravitational force (please see Einstein, 1918; Infeld quoted by Weber 1964, p. 97; Grishchuk 1974). Electromagnetic forces are more than 10^{35} larger than gravitational forces and should be employed in laboratory GW generation. As Weber (1964, p. 97) points out: “The non-gravitational forces play a decisive role in methods for detection and generation of gravitational waves ...” The quadrupole equation is also termed “quadrupole formalism” and holds in weak gravitational fields (but well over 100 g’s), for speeds of the generator “components” less than the speed of light and for the distance between two masses r less than the GW wavelength. This last restriction, although utilized in the derivation of the quadrupole equation, may not really apply. Certainly there would be GW generated for r greater than the GW wavelength, but the quadrupole “formalism” or equation might not apply exactly. For very small time change Δt the GW wavelength, $\lambda_{GW} = c \Delta t$ (where $c \sim 3 \times 10^8 \text{ ms}^{-1}$, the speed of light) is very small and the GW frequency ν_{GW} is high. As a numerical example, we will choose $r = 10 \text{ m}$ (convenient laboratory size though usually greater than λ_{GW}), $\Delta f = 4 \times 10^8 \text{ N}$ (or 400,000,000 N; for example, the force produced by a large number of piezoelectric resonators) and $\Delta t = 2 \times 10^{-10} \text{ s}$ (or 0.000,000,000,2 s; equivalent to about a $\nu_{GW} = 5 \text{ GHz}$ jerk or shake frequency) so that $\lambda_{GW} = 6 \text{ cm}$ and the power turns out to be $2.8 \times 10^{-13} \text{ W}$ (0.000,000,000,000,28 watts or 0.28 picowatts). Clearly a very small HFGW power generated.

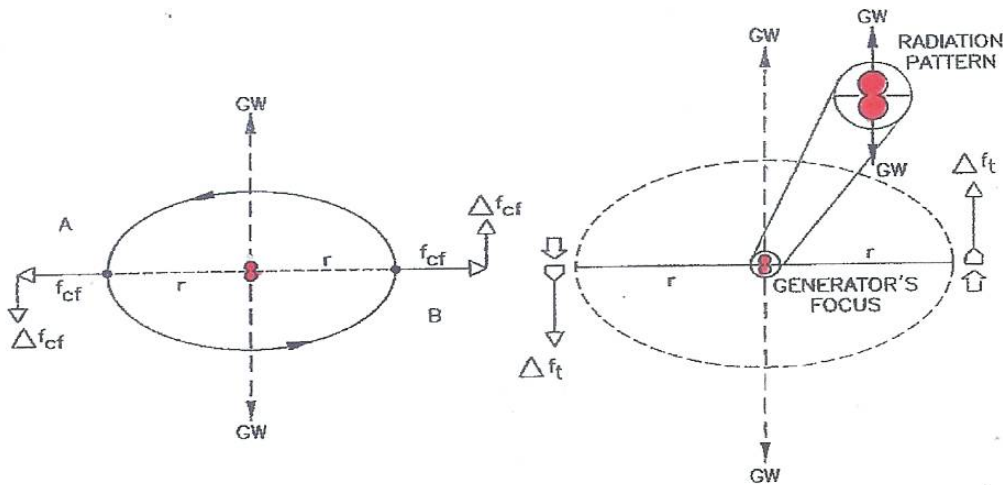

Figure 2.1.1. Change in Centrifugal Force of Orbiting Masses, Δf_{cf} , Replaced by Change in Tangential Force, Δf_t , to Achieve HFGW Radiation

One of the first suggested means for the laboratory generation of HFGWs was the so-called *gaser* analogous to the *laser* for light. Simply described (Halpern and Laurent, 1964), the *gaser* consists of a long rod of a material and microscopic parts of which can be excited by a means, such as electromagnetic (EM) radiation, to emit HFGWs. They utilize linearized theory to treat the interaction of a gravitational field with matter: “Application is made to the emission ... of gravitons by microscopic systems such as molecules and nuclei.” Grishchuk and Sazhin in early 1974 discussed the emission of gravitational waves by an electromagnetic cavity. In August of 1974 Chapline, Nuckolls and Woods suggested the generation of HFGWs by nuclear explosions. In this same regard Fontana suggested that the problem of efficient generation of HFGWs and pulses of gravitational radiation might find a reasonably simple solution by employing nuclear matter (Fontana and Baker, 2006; Fontana and Binder, 2009), especially isomers. A fissioning isomer not only rotates at extremely high frequency ($\sim 3.03 \times 10^{24} \text{ s}^{-1}$) according to the aforementioned references, but is also highly deformed in the first stages of fission (the nucleus is rotating and made asymmetric "before" fission). Thus one achieves significant impulsive forces (e.g., $3.67 \times 10^8 \text{ N}$) acting over extremely short time spans (e.g., $3.3 \times 10^{-22} \text{ s}$). Alternatively, a pulsed particle beam, which could include antimatter, could trigger nuclear reactions and build up a coherent GW as the particles move through a target mass. The usual difficulty with HFGWs generated by nuclear reactions is the small dimensions of their nuclear-reaction volumes, that is, the small moment of inertia and submicroscopic radii of gyration (e.g., 10^{-16} m) of the nuclear-mass *system*. Such a difficulty could be overcome by utilizing small clusters of nuclear material, whose nuclear reactions are in synchronization; for example, through the use of a computer controlled logic system. Such nuclear-energized HFGW generators are currently very

theoretical. Braginsky and Rudenko (1978) discussed the generation of gravitational waves in the laboratory and also proposed a means utilizing small particles. In 1981 Romero and Dehnen analyzed the generation of gravitational radiation in the laboratory utilizing a linear array of piezoelectric crystals that will be analyzed in more detail in section 2.1.3. In 1988 Pinto and Rotoli presented a paper on the laboratory generation of gravitational waves at the *Italian Conference on General Relativity and Gravitational Physics*. Another Italian, Giorgio Fontana (1998), suggested that the possibility of emission of high frequency gravitational radiation from junction between d-wave and s-wave superconductors. Kraus (1991), proposed that gravitational-wave communication might be possible in the *IEEE Antennas & Propagation Magazine*. At the first HFGW Working Group Conference at the MITRE Corporation in 2003 the Russian researcher Leonard Grishchuk analyzed electromagnetic generators and detectors of gravitational waves. At that same Conference another Russian Valentin Rudenko presented a paper on the optimization of parameters of a coupled generator-receiver for a “HFGW Hertz experiment.” At the second HFGW Working Group Conference in Austin, Texas, in 2007 Kolosnitsyn and Rudenko presented another paper on the generation and detection of the high-frequency gravitational radiation in a strong magnetic field. More recently there has been an as yet unpublished (at this writing) proposed HFGW generator by Raymond Y. Chiao (2007). Therefore it is evident that a number of devices for the laboratory generation of HFGWs have been proposed including an actual laser generator of HFGWs proposed by the Chinese as discussed by Baker, Li and Li (2006). Finally a rather practical laboratory HFGW generator, which may be appropriate for the initial proof-of-concept test, is one utilizing off-the-shelf components such as magnetron energized piezoelectric crystals or Film Bulk Acoustic Resonators or FBARs has been analyzed in Woods and Baker, (2005) and Baker, Woods and Li, (2006).

The *figure of merit* for a HFGW generator is given explicitly by Baker, Woods and Li (2006). This figure of merit can be extended by considering other effects. Since in the laboratory the force change could not even approach those of the celestial sources, it would seem that the magnitude of any laboratory generated GWs could be best increased as follows: (1) by utilizing electromagnetic forces rather than gravitational, (2) by increasing the distance between the gravitational radiators, (3) by increasing the GW frequency (that is, reducing Δt) and especially (4) by developing a large number of in-phase system elements. This last effect enters as the square of the number of elements, N , as proved using General Relativity analyses by Dehnen and Romero’s analyses (Romero and Dehnen, 1981; Dehnen and Romero, 2003). Such N^2 dependence also may be the key to successful laboratory generation of GWs, especially High-Frequency Gravitational Waves (HFGWs). The distance between GW radiators may be proportional to the GW wavelength in that it may have a limit that is less than or equal to a GW wavelength. The wavelength is inversely proportional to the GW frequency. Thus *given some value* for the proportional constant, say unity or the distance between radiators equal to one GW wavelength, the GW frequency cancels out for that special situation. As already noted it is important to take advantage of square of the number of in-phase elements for useful laboratory HFGW generation. If we slice the elements in one dimension (the dimension along the axis of HFGW generation) in order to increase the number of elements, then the change in force per element will be inversely proportional to the number of elements. For

example, if the elements are sliced into one hundred separate pieces, then each piece will have one hundredth of the force of the unsliced element. Essentially, $f = ma$ and it is assumed that the acceleration of the element was the same after the split as before. This result also follows Eq. (8), page 17 of <http://www.gravwave.com/docs/Analysis%20of%20Lab%20HFGWs.pdf> and if there were 100 splits of an FBAR, then the power to an individual slice, P and its mass, m would be both one hundredth of their un-split value and the square root of their product would again be one hundredth. The frequency of the split elements may be a higher value -- but the attendant increase in GW power proportional to the square of the higher frequency and the decrease in power due to a smaller distance between tracks (assuming that the distance between tracks, $2r$ in Figs. 2.1.1 and 2.1.3a, is one GW wavelength, which would be smaller) would cancel and there would be no net effect on HFGW amplitude. It is concluded, therefore, that in this *particular special situation* the amplitude of the generated HFGWs is proportional to the number of in-phase elements, N (not the square). In any event a large number of elements for a given HFGW-generator length can be best realized by reducing the size of the individual elements to submicroscopic size (as discussed in U. S. Patent Number 6,784,591).

2.1.2 Alternative Approaches

As discussed in the preceding section 2.1.1, there are several alternative approaches to the laboratory generation of HFGWs developed over the past 45 years. As already mentioned their theories are published in peer-reviewed journals and include the Russians: Grishchuk and Sazhin (1974), Braginsky and Rudenko (1978), Rudenko (2003), Kolosnitsyn and Rudenko (2007); the Germans: Romero and Dehnen (1981) and Dehnen and Romero-Borja (2003); the Italians: Pinto and Rotoli (1988), Fontana (2004); Fontana and Baker (2006); the Chinese: Baker, Li and Li (2006). They can be categorized as EM-cavity generated, nuclear-energy generated, superconductor-generated, laser-impact generated, energized microscopic & submicroscopic-particle and piezoelectric crystal (commercially available in cell-phones as Film Bulk Acoustic Resonators or FBARs) generated HFGWs. Of these categories the last category appears to be the most promising for early deployment in HFGW communications systems. Furthermore, one embodiment of that category, the Magnetron-energized FBARs generator, utilizing off-the-shelf equipment, would seem the most useful for proof-of-concept tests. For a practical, operational communications system HFGW generator (transmitter) the strong dependence of HFGW generator's power on the number of radiating elements, N , recommends a system utilizing molecular elements as suggested by Braginsky and Rudenko (1978), but that system may not be realizable soon. The Magnetron-energized FBARs will be considered in the next-following section.

2.1.3 Piezoelectric-Crystal Approach

The generation of HFGWs in the laboratory or the HFGW transmitter is based upon the well-known astrodynamics gravitational-wave generation process (Landau and Lifshitz (1975)). In Fig. 2.1.3a is shown the gravitational wave (GW) radiation pattern for orbiting masses in a single orbit plane where f_{cf} is the centrifugal force and Δf_{cf} is the

change in centrifugal force, acting in opposite directions, at masses **A** and **B**. Next consider a number N of such orbit planes stacked one on top of another again with the gravitational-wave (GW) radiation flux (Wm^{-2}) growing as the GW moves up the axis of the N orbit planes as in Fig. 2.1.3b . We now replace the stack of orbital planes by a stack of N HFGW-generation elements. These elements could be pairs of laser targets (Baker, Li and Li, 2006), gas molecules (Woods and Baker, 2009), piezoelectric crystal pairs (Romero-Borja and Dehnen, 1981; Dehnen and Romero-Borja, 2003) or film-bulk acoustic resonator (FBAR) pairs, which also are composed of piezoelectric crystals (Woods and Baker, 2005). Since they can be obtained off the shelf we select the FBAR alternative. Thus we now have a HFGW wave moving up the centerline of the FBAR-pair tracks, as shown in Fig. 1 of Baker (2009). Note that FBARs are ubiquitous and are utilized in cell phones, radios and other commonly used electronic devices and that they can be energized by conventional Magnetrons found in Microwave Ovens and can be miniaturized.

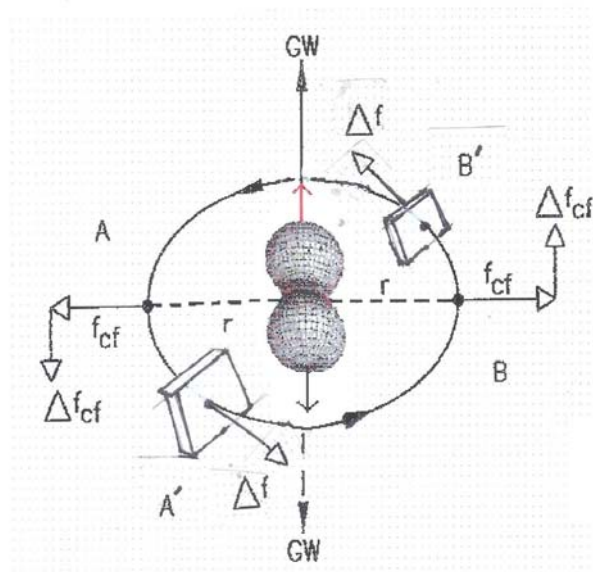

**Figure 2.1.3a. Radiation pattern calculated by Landau and Lifshitz (1975)
Section 110 Page 356.**

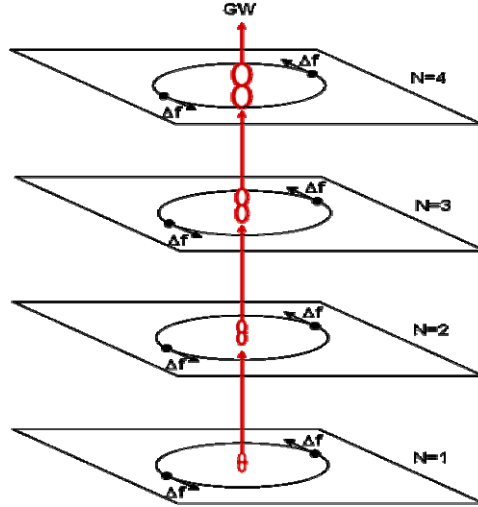

Figure 2.1.3b. GW Flux Growth Analogous to Stack of N Orbital Planes

The HFGW flux or signal increases in proportion to the square of the number HFGW-generation elements, N . The N^2 build up is attributed to two effects: one N from there being N HFGW power sources or generation elements and the other N from the narrowing of the beam so that the HFGW is more concentrated and the flux (Wm^{-2}) thereby increased (Romero-Borja and Dehnen, 1981; Dehnen and Romero-Borja, 2003). Note that it is not necessary to have the FBAR tracks perfectly aligned (that is the FBARs *exactly* across from each other) since it is only necessary that the energizing wave front (from Magnetrons in the case of the FBARs as in Baker, Woods and Li (2006)) reaches a couple of nearly opposite FBARs at the same time. The HFGW beam is very narrow, usually less than 10^{-4} radians (Baker and Black, 2009). Additionally multiple HFGW carrier frequencies can be used, so the signal is very difficult to intercept, and is therefore useful as a low-probability-of-intercept (LPI) signal, even with widespread adoption of the technology. The force change, Δf , produced by a single off-the-shelf FBAR is 2 N (for 1.8×10^8 FBARS the force change is 4×10^8 N or about 2 N per FBAR according to Woods and Baker (2005)). The basic equation for the GW power produced by a change in force pair such as FBARs, P , as derived in Baker (2006), is:

$$P = 1.76 \times 10^{-52} (2r \Delta f / \Delta t)^2 \text{ W}, \quad (2.1.3.1)$$

where $2r$ is the distance between the FBAR pair (or between “tracks”), m, Δf is the force change, N and Δt is the time over which the force change occurs, s or the inverse of the HFGW frequency, $1/v_{\text{GW}}$. As can be seen from Fig. 2.1.3a the fixed (not orbiting) FBARs are faced (i.e., the normal to their flat surface in the Δf direction) tangent to the circle at **A'** and **B'**. From p.1282 of Baker, Woods and Li (2006) in plan form the flat surface is $100\mu\text{m} \times 100\mu\text{m}$ and they are about $1 \mu\text{m}$ thick. To allow for margins we will take the FBAR dimensions overall as $110 \times 110 \times 2 \mu\text{m}^3$. Consider a double-helix arrangement of the FBAR tracks as discussed in Baker and Black (2009) and exhibited in Fig. (2.1.3c). Let n FBARs be spread out radially like a vane as one proceeds up the helixes

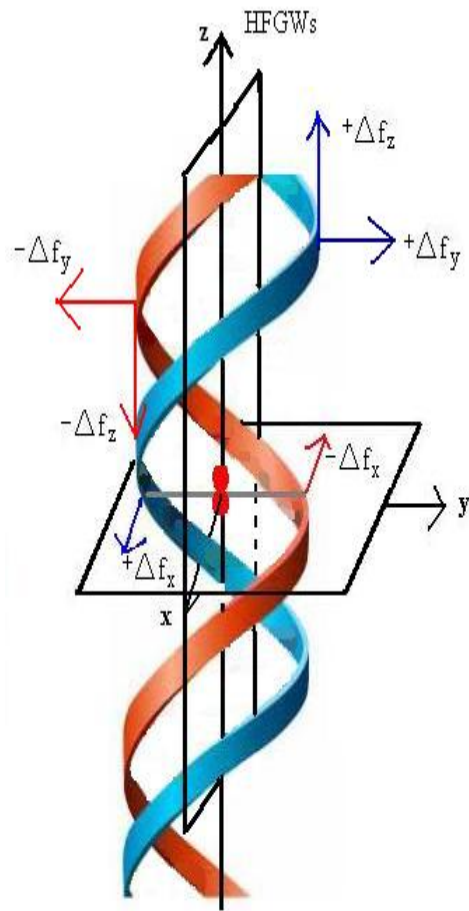

Figure 2.3.1c. Double-Helix HFGW Generator FBAR Array (Patent Pending).

Thus $\Delta f = 2nN$. If $n = 1000$, then the radial extent of the FBARs vane would be 11 cm. For $r = 1\text{m}$, $\Delta f = 2000\text{ N}$ and $v_{\text{GW}} = 4.9\text{ GHz}$, the HFGW generated by the i^{th} FBAR vane pair is $P_i = 6.76 \times 10^{-26}\text{ W}$. Note that $2r = 2\text{ m}$ is greater than the HFGW wavelength $\lambda_{\text{GW}} = 6.1\text{ cm}$. Nevertheless, according to page 1283 of Baker, Woods and Li (2006) Eq. (2.1.3.1) or “quadrupole formalism” is still approximately valid (see also Section 2.1.1). From Eq. (6) and Table 2 (for 10^0 half angle at $N=1$) of Baker and Black (2009) we have for the signal, $S(1.0)$, or flux, $F(1.0)$, at 1.0 meter from the end of an array of N FBAR vane pairs

$$S(1.0) = F(1.0) = N^2 F(1.0)_{N=1} = N^2 (0.336) P_i. . \quad (2.1.3.2)$$

Let us place the FBAR vane pairs adjacent to each other on the helix ribbons or tracks so that there will be $2\pi r/2\mu = 3.14 \times 10^6$ vane pairs on each $110\ \mu\text{m}$ thick level leading up a cylindrical helical FBAR array (US Patents 6,417,597 and 6,784,591 and Patents Pending). We will “stack” these $110\ \mu$ thick levels one on top of the other in the double-helix configuration (Baker and Black, 2009). There will be $10\text{m}/110\ \mu\text{m} = 9.1 \times 10^4$ levels so that $N = 2.9 \times 10^{11}$. Thus, from Eqs. (2.1.3.1) and (2.1.3.2), we have $S = 1.9 \times 10^{-3}\text{ Wm}^{-2}$ at a one meter distance or if we were $1.3 \times 10^7\text{ m}$ (diameter of Earth) distance, then $S = 1.12 \times 10^{-17}\text{ Wm}^{-2}$. From Eq. (2.1.3.3), derived in the Appendix of Baker, Stephenson and Li (2008), the amplitude A (dimensionless strain of the spacetime fabric) of the HFGW is given by:

$$A = 1.28 \times 10^{-18} \sqrt{S/v_{\text{GW}}}\text{ m/m}, \quad (2.1.3.3)$$

so that $A = 8.8 \times 10^{-37}\text{ m/m}$. The sensitivity of the Li-Baker HFGW detector is on the order of 10^{-32} m/m , but its sensitivity can be increased dramatically by introducing superconductor resonance chambers (Li and Baker, 2007) into the interaction volume (which also improves the Standard Quantum Limit as discussed in 2.2.3) and two others between the interaction volume and the two microwave receivers. Together they provide an increase in sensitivity of five orders of magnitude and result in a sensitivity of the Li-Baker detector to HFGWs having amplitudes of 10^{-37} m/m . Since the exact frequency and phase of the HFGW signal is known (unlike big-bang relic HFGWs, for which the Li-Baker detector was designed (as shown in Fig. 4 from Grishchuk (2008) that exhibits the 10 GHz peak in relic HFGW energy density), a much more sensitive, optimized HFGW detector will likely be developed. Such a sensitive detector will still not be quantum limited (Stephenson, 2009b). The power required at $2 \times 56\text{ mW}$ per FBAR pair (Woods and Baker, 2005) would be about $2 \times n \times N \times 56 \times 10^{-3} = 3.2 \times 10^{13}\text{ W}$. Thus to reduce the average power to, say 32 MW for a conventional commercial substation, one could communicate with one microsecond bursts every second (roughly a 49 kHz information bandwidth). One would still need about 32 thousand off-the-shelf Microwave-Oven-type, in-phase, one kW Magnetrons distributed along the cylinder walls. The Magnetron would be angled up along the direction of the HFGW beam in the double helix and produce about a kilowatt of average power, but with MW burst capability. The frequency-standard optimized FBARs would be replaced by Δf optimized ones. The cost should be less than

20 to 30 million dollars US or a small fraction of the cost of the LIGO, Virgo and GEO600 LFGW detectors. The very speculative use of superconductor GW lenses (US Patent 6,784,591) and mirrors (such mirrors suggested by Baker (2003), Woods (2006), Chiao, et al. (2009) and Minter, et al. (2009), *but in a concave parabolic mosaic form* (Baker, 2003 and 2005)) would serve to further concentrate the HFGWs and increase their amplitude A at the detector/receiver and greatly improve the information bandwidth.

2.2 HFGW Detectors (Receivers)

2.2.1 Alternative Approaches

One of the first suggested means for the detection of HFGWs was by the Russians and concerns electromagnetic detectors (Braginsky, et al. 1974 and Braginsky and Rudenko, 1978). Then the Italians Pegoraro, et al. (1978) suggested the use of tuned resonant chamber HFGW detectors. Rudenko and Sazhin in 1980 proposed a Laser interferometer as a HFGW detector (somewhat similar to the current Japanese approach as shown in Fig. 2.2.1c). In 1995 Tobar characterized multi-mode resonant-mass HFGW detectors and three years later in 1998 Ottaway, et al. proposed a compact injection-locked Nd:YAG laser for HFGW detection. And in 1999 Tobar again suggested, microwave parametric transducers for the next generation of resonant-mass gravitational wave HFGW detectors.

In the past few years HFGW detectors, as exhibited in Figs. 2.2.1a, 2.2.1b and 2.2.1c, have been fabricated at *Birmingham University*, England, *INFN Genoa*, Italy and in Japan. These types of detectors may be promising for the detection of the HFGWs in the GHz band (MHz band for the Japanese) in the future, but currently, their sensitivities are orders of magnitude less than what is required for the detection of high-frequency relic gravitational waves (HFRGWs) from the big bang. Such a detection capability is to be expected, however, utilizing the **Li-Baker** detector. Nevertheless, all four candidate detectors; plus, possibly, the use of superconductors (Li and Baker, 2007) should be analyzed for possible communication applications. The Li-Baker HFGW detector was invented by R. M L Baker, Jr. of Transportation Sciences Corporation, California and patented

<http://www.gravwave.com/docs/Chinese%20Detector%20Patent%2020081027.pdf>.

Based upon the theory of Li, Tang and Zhao (1992) termed the **Li-effect**, the detector was proposed by Baker during the period 1999-2000, a patent for it was filed in P. R. China in 2001, subsequently granted in 2007, and preliminary details were published later by Baker, Stephenson and Li (2008). This detector was conceived to be sensitive to relic HFGWs (HFRGWs) having amplitudes as small as 10^{-32} to 10^{-30} , but using resonance chambers to 10^{-37} or possibly smaller as already mentioned.

The Birmingham HFGW detector measures changes in the polarization state of a microwave beam (indicating the presence of a GW) moving in a waveguide about one meter across as shown in Fig. 2.2.1a. (Please see Cruise (2000); Ingley and Cruise (2001) and Cruise and Ingley (2005)). It is expected to be sensitive to HFGWs having spacetime strains of $A \sim 2 \times 10^{-13} / \sqrt{\text{Hz}}$, where Hz is the GW frequency, and as usual A is a measure of the strain or fractional deformation in the spacetime continuum (dimensionless m/m).



Figure 2.2.1a. Birmingham University HFGW Detector.

The *INFN Genoa* HFGW resonant antenna consists of two coupled, superconducting, spherical, harmonic oscillators a few centimeters in diameter. Please see Fig. 2.2.1b. The oscillators are designed to have (when uncoupled) almost equal resonant frequencies. In theory the system is expected to have a sensitivity to HFGWs with size (fractional deformations) of about $A \sim 2 \times 10^{-17} / \sqrt{\text{Hz}}$ with an expectation to reach a sensitivity of $\sim 2 \times 10^{-20} / \sqrt{\text{Hz}}$. (Bernard, Gemme, Parodi, and Picasso (2001); Chincarini and Gemme (2003)). As of this date, however, there is no further development of the *INFN Genoa* HFGW detector.



Figure 2.2.1b. INFN Genoa HFGW Detector.

The Kawamura 100 MHz HFGW detector has been built by the *Astronomical Observatory of Japan*. It consists of two synchronous interferometers exhibiting an arms length of 75 cm. Please see Fig. 2.2.1c. Its sensitivity is now about $A \approx 10^{-16}/\sqrt{\text{Hz}}$ (Nishizawa et al., 2008). According to Cruise (2008) of *Birmingham University* its frequency is limited to 100 MHz and at higher frequencies its sensitivity diminishes. In the case of the Infra-red-excited molecules approach, one might employ a variant of the Robinson Gravitational Wave Background Telescope for the receiver or detector (Yoon, et al., 2006). It is a bolometric large-angular-scale Cosmic Microwave Background (CMB) polarimeter, but might possibly be modifiable for direct HFGW detection. Another indirect HFGW detector that might be modified and utilized is termed “QUIET” and discussed in Lawrence (2004).

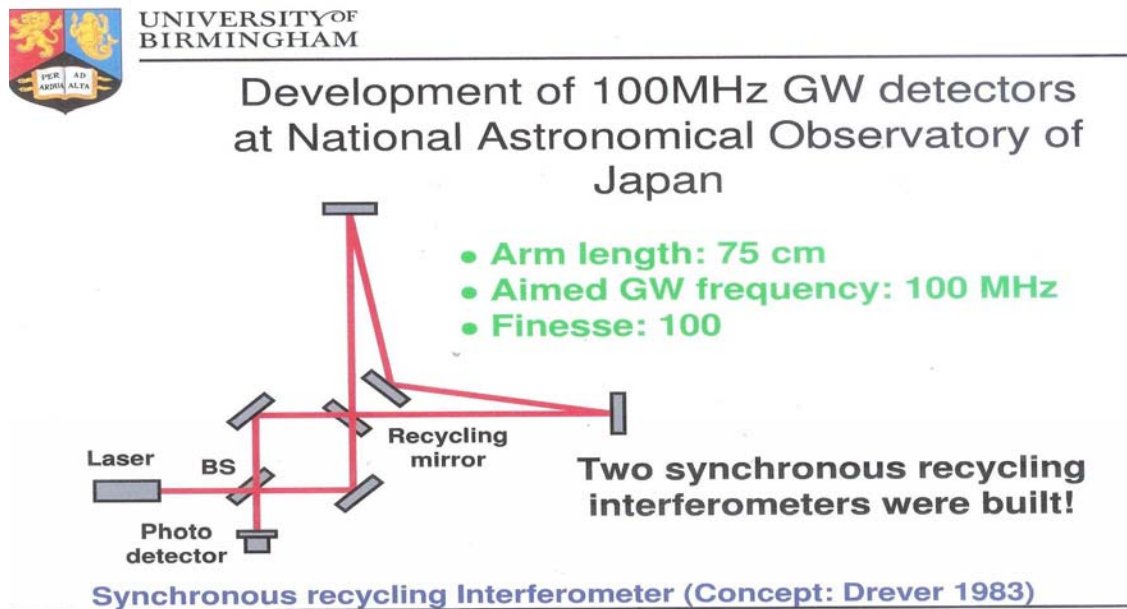

Figure 2.2.1c. The National Astronomical Observatory of Japan 100MHz Detector. Cruise (2008).

2.2.2 Concept (Li-Effect)

The **Li-Effect** or **Li-Theory** was first published in 1992. Subsequently the “Li Effect” was validated by eight journal articles, independently peer reviewed by scientists presumably well versed in general relativity, (Li, Tang and Zhao, 1992; Li and Tang, 1997; Li, Tang, Luo, 2000; Li, Tang and Shi, 2003; Li and Yang, 2004; Li and Baker, 2007; Li, et al., 2008; Li, et al., 2009) including capstone papers, Li, et al.(2008) and Li et al. (2009). The Li-Effect is *very different* from the classical (*inverse*) Gertsenshtein-Effect. With the Li-Effect, a gravitational wave transfers energy to a separately generated electromagnetic (EM) wave in the presence of a static magnetic field. That EM wave has the same frequency as the GW and moves in the same direction. This is the “*synchro-resonance condition*,” in which the EM and GW waves are synchronized and is **unlike**

the Gertsenshtein-Effect. The result of the intersection of the parallel and superimposed EM and GW beams, according to the Li-Effect, is *new EM photons moving off in a direction perpendicular to the beams and the magnetic field directions*. These photons signal the presence of HFGWs and are termed a “perturbative photon flux or PPF. Thus, these new photons occupy a separate region of space (see Fig. 2.2.2) that can be made essentially noise-free and the synchro-resonance EM beam itself (in this case a Gaussian beam) is not sensed there, so it does not interfere with detection of the photons. In this connection it should be recognized that *unlike the Gertsenshtein effect*, the Li-effect produces a *first-order* perturbative photon flux (PPF), proportional to the amplitude of the gravitational wave (GW) A not A^2 . In the case of the Gertsenshtein-Effect such photons are a second-order effect and according to Eq. (7) of Li, et al. (2009) the number of EM photons are “...proportional to the amplitude squared of the relic HFGWs, A^2 ,” ... and that it would be necessary to accumulate such EM photons for at least 1.4×10^{16} seconds in order to achieve relic HFGW detection (Li et al., 2009) utilizing the Gertsenshtein-Effect. In the case of the Li theory the number of EM photons is proportional to the amplitude of the relic HFGWs, $A \approx 10^{-30}$, not the square, so that it would be necessary to accumulate such EM photons for only about 1000 seconds in order to achieve relic HFGW detection (Li et al., 2008)). The JASON report (Eardley, 2008) confuses the two effects and erroneously suggests that the Li-Baker HFGW Detector utilizes the inverse Gertsenshtein effect. It does not and does have a theoretical sensitivity that is about $A/A^2 = 10^{30}$ greater than that incorrectly assumed in the JASON report.

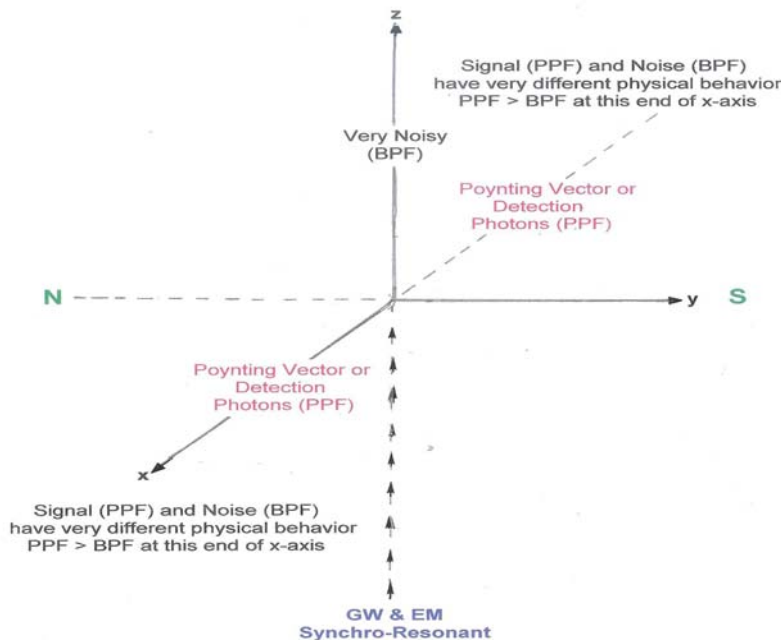

Figure 2.2.2. Detection Photons Sent to Locations that are Less Affected by Noise.

The synchro-resonance solution of Einstein’s field equations (Li, Baker, Fang, Stephenson and Chen, 2008 pp. 411 to 413) is radically different from the Gertsenshtein (1962) effect. *Unlike the Gertsenshtein effect*, a *first-order* perturbative photon flux

(PPF), comprising the detection photons, will be generated in the x -direction. Since there is a 90 degree shift in direction, there is little crosstalk between the PPF and the superimposed EM wave (Gaussian beam), so the PPF signal can be isolated and distinguished from the effects of the Gaussian beam, enabling detection of the GW.

2.2.3 Quantum Back-Action Limit

The Standard Quantum Limit (SQL) will be introduced and reviewed in this section (from Stephenson, 2009b), and design of the Li-Baker HFGW Detection System will also be reviewed to understand how the SQL might limit the sensitivity of this new type of GW detector.

Review of the Standard Quantum Limit

The Standard Quantum Limit (SQL) is often defined as “The limit on measurement accuracy at quantum scales due to back-action effects.” But what is “back-action”? (See Kippenberg and Vahala, 2008.) From Clerk (2008) the Heisenberg Uncertainty Principle is

$$(\Delta x) \times (\Delta p) > \hbar/2 \quad (2.2.3.1)$$

where Δx is the position uncertainty, Δp is the momentum uncertainty, and \hbar is Planck’s constant divided by 2π . Thus measuring x disturbs p , which in turn disturbs future measurements of x

$$\Delta x(dt) = \Delta x(0) + dt[\Delta p(0)/m], \quad (2.2.3.2)$$

where $\Delta x(0)$ is the initial position uncertainty, $\Delta p(0)$ is the initial momentum uncertainty, dt is the time of the future measurement, and m is the mass of the system under measurement. E/c^2 may be substituted for mass in an energy-only system. This is depicted in Fig. 2.2.3a.

To summarize, the quantum effects of measurements on future measurements is “quantum back action.” Therefore the Standard Quantum Limit defines the lower sensitivity limit for all measurement instruments, including gravitational-wave detectors, according to the Heisenberg uncertainty principle. Detectors can not avoid quantum back action, however the use of higher energies in the detection process can change the relative scale and impact of back action, and the use of squeezed states can shift the relative distribution of back action into states not involved in measurement.

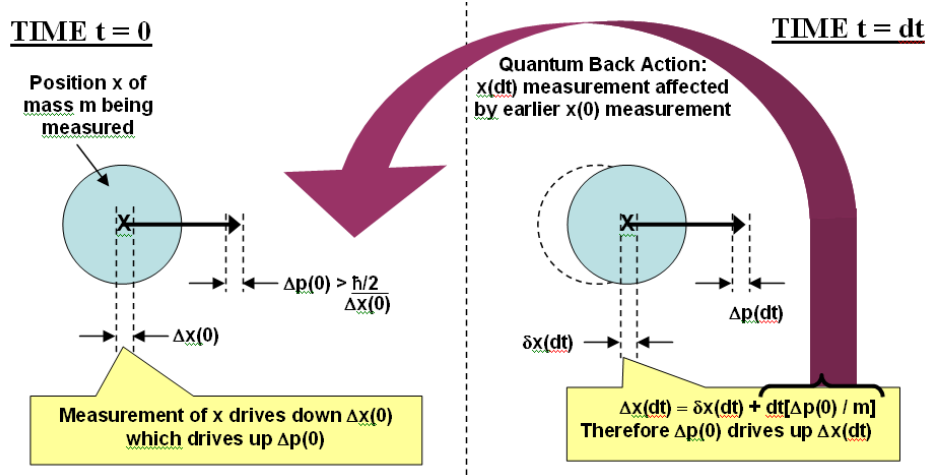

Figure 2.2.3a. An Example of how Quantum Back Action is the Mechanism for Creating the Standard Quantum Limit.

Calculating the Standard Quantum Limit (SQL)

A method for calculating the Standard Quantum Limit (SQL) is introduced in this section. The calculation of coherent versus stochastic SQL is compared and contrasted. Important terms of the SQL calculation are described, including the impact of contained energy levels within the detector on SQL, and the sources of Quality Factor and its effect on SQL.

Coherent versus Stochastic SQL

The question under consideration in this section is whether or not the Li-Baker detector, Figs.2.2.2 and 2.2.4a, is quantum-limited when detecting relic HFGW. In other words, does the standard quantum limit (SQL) interfere with the sensitivity of the Li-Baker detector design? The answer will be negative if the SQL is less than 10^{-32} m/m. Grishchuk (1977; 2007) has calculated the SQL for GW detectors in general, which for a coherent GW is

$$h_{det} = (1/Q)(\hbar\omega/E)^{1/2} \quad (2.2.3.3)$$

and for a stochastic GW is:

$$h_{det} = (1/Q)^{1/2}(\hbar\omega/E)^{1/2}, \quad (2.2.3.4)$$

where h_{det} is the metric (strain variation in the fabric of spacetime whose amplitude is A) detection limit in m/m, ω is the frequency of sensed gravitational waves (typically around 10GHz for the Li-Baker detector), E is the effective energy contained within the detector cavity summed over the detection averaging time, and Q is the quality factor or selectivity of the signal over noise.

The SQL depends on the values of these parameters. For the remainder of this section, we will consider the SQL of only the stochastic signal detection case. In the following subsections the best possible value of the SQL using current technology will be estimated to determine the fundamental limitations of the Li-Baker detector as now envisioned.

Impact of Contained Energy Levels on SQL

Let us first attempt to estimate a realistic best case for the energy contained within the detection process, E . Typically it is expected that for a refrigerated interaction volume (or microwave resonant cavity if introduced to amplify the PPF) the best possible electrical quality factor will be around $2\pi \times 10^5$. Assuming a “best efforts” value of 1000W for the power of the Gaussian beam in a laboratory installation, the effective total RF energy stored in the microwave resonant cavity of the Li-Baker detector, summed over the system averaging time, is estimated to be given by (Grishchuk, 2007):

$$E_{RF} = (10^3 W) \times (1000s) \times (2\pi \times 10^5 / 2\pi) = 10^{11} J m^{-3} \quad (2.2.3.5)$$

over a typical 1000s averaging time. (Use of a resonance cavity (Li and Baker, 2007) in the interaction volume might increase E by a factor of one hundred or one thousand.) Both the Li-Baker detector and a detector using the Gertsenshtein effect use a large static magnetic field B . For the present suggested outline design for the Li-Baker detector, the nominal value of $B = 16T$, so that the magnetic energy density is given by

$$E_B = (1/2)B^2 / (\mu_r \mu_0) = 1.02 \times 10^8 J m^{-3}. \quad (2.2.3.6)$$

The interaction volume in a practical laboratory-based detector is likely to be a maximum of around $1 m^3$. So, the effective total stored energy from the Gaussian beam is much greater than the stored magnetic field energy, and it follows that $E \approx E_{RF} = 10^{11} J$ to a reasonable approximation.

Sources of Quality Factor and Effect on SQL

To calculate the SQL, h_{det} , we also need the value of the detector quality factor Q (not the same as the cavity quality factor). Anything that concentrates or enhances the signal preferentially over noise, in any measurement dimension, can be considered a contributor to the quality factor Q (including labeling **B**, section 3.1.1 or the use of a resonance cavity). The quality factor can therefore be understood as the “signal selectivity” in each dimension, so that

$$Q_{tot} = (Q_{spatial})(Q_t) = Q_r Q_{solid\ angle} Q_t. \quad (2.2.3.7)$$

The temporal quality factor in the Li-Baker detector arises from averaging the signal over time, so that at 10 GHz, $Q_t = \Omega \cdot t_{int} = 10 \times 10^9 Hz \times 1000s = 10^{13}$.

There is also a contribution to Q arising from the semi-paraboloid mirror that focus and concentrate the signal photon energy (traveling in the x directions) – but not the background photons – traveling mainly in the z direction. The radial selectivity arising from the general relativity solution, in conjunction with focusing mirrors, is calculated by Li *et al.* (2008). Their table III gives $Q_r = SNR_{(r=37cm)}/SNR_{(r=3.5cm)} = 3.4 \times 10^{21}$.

This is mostly due to the effective Q contribution arising from the synchro-resonance solution to the Einstein field equations that limit the PPF signal to a radiation pattern in certain directions, whereas noise is distributed uniformly. By utilizing directional antennas, the Li-Baker detector can capitalize upon this gain due to the focusing power of the semi-paraboloid mirror as a contribution to Q in angular space as well. This is calculated in detail, octant by octant, by Li *et al.* (2008). Page 24 of Li *et al.* summarizes this in terms of angular concentration onto the detector. A non-directional antenna corresponds roughly to solid angle 2π steradians (one hemisphere), so that the effective antenna gain is estimated as $(Q_{solid\ angle}) = 2\pi\ sr/10^{-4}\ sr = 6.3 \times 10^4$. Therefore, the predicted maximum quality factor will be $Q_{total} = Q_r Q_{solid\ angle} Q_t = 2.1 \times 10^{39}$ (as already noted the possibility of using the “labeling” of \mathbf{B} described in 3.1.1 and use of a resonance cavity in the interaction volume would also increase Q). This finally gives the Standard Quantum Limit (SQL) for stochastic GW detection at 10 GHz:

$$h_{det} = (1/Q)^{1/2} (\hbar\omega/E)^{1/2} = 1.8 \times 10^{-37} m/m. \quad (2.2.3.8)$$

Comparison of SQL with Predicted Sensitivity

As noted in the previous section, $h_{det} = 1.8 \times 10^{-37} m/m$ (strain variation in the fabric of spacetime whose amplitude is A) represents the lowest possible GW strain variation detectable by each RF receiver in the Li-Baker HFGW detector, limited by quantum back-action. An additional $(1/\sqrt{2})$ factor applies if the separate outputs from the two RF receivers are averaged, rather than used independently for false alarm reduction, resulting in a minimum $h_{det} = 1.2 \times 10^{-37}$. Since the predicted best sensitivity of the Li-Baker detector in its currently proposed configuration is $A = 10^{-32} m/m$, these results confirm that the Li-Baker Detector is photon-signal limited, not quantum noise limited; that is, the Standard Quantum Limit is so low that a properly designed Li-Baker detector can have sufficient sensitivity to observe HFRGW of amplitude $A \approx 10^{-32} m/m$.

2.2.4 Li-Baker HFGW Detector

The detector, shown schematically in Fig. 2.2.4a, has five major components and several noise sources that are discussed in the following:

1. A Gaussian microwave beam or GB (focused, with minimal side lobes and off-the shelf microwave absorbers for effectively eliminating diffraction at the transmitter horn’s edges, shown in **yellow** and **blue** in Figs. 2.2.4b, 2.2.4c and 2.2.4d) is aimed along the $+z$ -axis at the same frequency as the intended HFGW signal to be detected (Yariv, 1975).

The frequency is typically in the GHz band exhibiting a single (“monochromatic”) value such as 10 GHz (in the case of HFRGW or big-bang detection), and also approximately aligned in the same direction as the HFGW to be detected. The microwave transmitter’s horn antenna would be located on the $-z$ axis and a microwave absorbing device at other end of the z axis (Fig. (2.2.4D)). The microwave generation and microwave absorbing equipment would be in separate enclosures or chambers sealed off by microwave transparent walls from the main detector chamber and shielded and thermally isolated. The absorption of the actual GB in the isolated GB-absorption enclosure is only a problem of conducting the heat away from the array of absorbing material to a cooler that is external to the main detector enclosure or chamber to be located at some distance out from the main detector compartment.

2. A static magnetic field \mathbf{B} , generated by three magnets (typically using superconductor magnets such as those found in a conventional MRI medical body scanner) and installed linearly along the z -axis, is directed (N to S) along the y -axis as shown schematically in Fig. (2.2.2). The intersection of the magnetic field and the GB defines the “interaction volume” where the detection photons or PPF are produced. The interaction volume for the present design is roughly cylindrical in shape about 30cm in length and 9cm across.

3. A semi-paraboloid reflector is situated in the y - z plane, as shown in Fig. 2.2.4b to reflect the $+x$ and $-x$ moving PPF detection photons on both sides of the y - z plane, in the interaction volume, to the microwave receivers. The Sagitta of such a reflector (60 cm effective aperture) is about 2.26 cm. Since this greater than a tenth of a wavelength of the detection photons, $\lambda_e/10 = 0.3$ cm, such a paraboloidal reflector is required rather than a plane mirror (also, for enhanced noise elimination, the reflector’s focus is below the x axis and “out of sight” of the GB’s entrance opening). Since such a reflector would extend out 2.26 cm into the GB (on both sides of y - z plane or 4.5 cm in total) a half or semi-paraboloid mirror is used instead. The reflector will be about 30 cm high (along the z -axis) and 9 cm wide (along the y -axis) and extend from $z = 0$ cm to $z = +30$ cm as shown in Figs. 2.2.4b and 2.2.4c. The reflector will be installed to reflect x -directed photons to the two or more microwave receivers on the x -axis at $x = \pm 100$ cm from the reflector array (as already noted there could be several microwave receivers stacked at each end of the x -axis to increase the field of view and account for any variations in the magnetic field from uniform straight lines). The semi-paraboloid reflector extends from a sharp edge at point **A** in Fig. 2.2.4b at the center of the Gaussian beam (GB). Thus there will be almost no blockage of the GB. The reflectors can be constructed of almost any material that is non-magnetic (to be unaffected by the intense magnetic field), reflects microwaves well and will not outgas in a high vacuum.

4. High-sensitivity shielded microwave receivers are located at each end of the x -axis. Alternative microwave receivers include an off-the-shelf microwave horn plus HEMT receiver, Rydberg-Cavity Receiver, and circuit QED microwave receiver. Of these the HEMT receiver is selected because of its off-the-shelf availability. If the \mathbf{B} field is not uniformly straight or if the field of view needs to be larger, then additional microwave receivers can be arranged in an array at $x = \pm 100$ cm in a plane parallel to the y - z plane.

5. A system able to evacuate the chamber to about 10^{-6} to 10^{-11} Torr (nominally about 7.5×10^{-7} Torr) will be utilized. This is well within the state of the art, utilizing multi-stage pumping, and is a convenient choice. The required criterion for the cooling system is that the temperature T satisfies $k_B T \ll \hbar \omega$, where k_B is Boltzmann's constant and $T \ll \hbar \omega / k_B \approx 3\text{K}$ for detection at 10GHz. This condition is satisfied by the target temperature for the interaction volume $T < 480\text{mK}$, which can be conveniently obtained using a common helium-dilution refrigerator so that no thermal photons will be radiated at 10 GHz.

6. Ideally the Gaussian beam is a culminated beam having distinct edges. In actuality it is not, but falls off exponentially. In the prototype under analysis, which has peak sensitivity at 10 GHz, the energy per detection photon is $h\nu_e = 6.626 \times 10^{-34} \text{ (Js)} \times 10^{10} \text{ (s}^{-1}\text{)} = 6.626 \times 10^{-24} \text{ (J)}$, so for a 1,000 W GB, the total photons per second for the entire beam is 1.51×10^{26} photons per second. At the 100-cm-distant microwave receivers, the theoretical GB intensity is reduced to $\exp(-2 \times 100^2 / 4.3^2) (1.51 \times 10^{26})$, **which is essentially zero.**

7. With regard to the background photon flux (BPF) or noise BPF from the scattering in the Gaussian beam, we introduce hydrogen or helium into the detector enclosure prior to evacuating it to reduce the molecular cross-section and, therefore, increase the mean free path. The photon mean free path, l , for helium gas molecules at a high-vacuum pressure of 7.5×10^{-7} Torr (9.86×10^{-10} atmospheres) and temperature of 480mK, is given by (diameter d of a He molecule is 1×10^{-8} cm):

$$l = 1/(n\sigma) = 1/([N_m P/T][\pi d^2/4]) = 1/([1.51 \times 10^{13}][7.85 \times 10^{-17}]) = 844 \text{ cm}, \quad (2.2.4.1)$$

where N_m = number of molecules in a cm^3 at standard temperature and pressure (STP) = 2.7×10^{19} , P is the pressure in atmospheres and T is temperature in degrees Kelvin or the ratio of the temperature at STP to that in the detector. Since 844 cm is far longer than the 30 cm long interaction volume, there will be negligible degradation of the EM-GB interaction due to intervening mass. With regard to scattering, $\lambda_e = 3 \text{ cm} = 3 \times 10^8 \text{ \AA}$ (wavelength of the GB's EM radiation) is very much greater than the diameter of the He molecule (1×10^{-8} cm), so there would be Rayleigh scattering (caused by particles much smaller than the wavelength of the EM radiation). The average scattering cross section (σ_{ray}) per H_2 molecule (about the same as per He_2 molecule) is given by $\sigma_{\text{ray}}(\text{H}_2) = (8.48 \times 10^{-13} / \lambda_e^4 + 1.28 \times 10^{-6} / \lambda_e^6 + 1.61 / \lambda_e^8) \text{ cm}^2$ (with λ_e in \AA) = $1.047 \times 10^{-46} \text{ cm}^2$. Thus the Rayleigh scattering mean free path is

$$l_{\text{ray}} \approx 1/(n\sigma_{\text{ray}}) = 1/([N_m P/T][\sigma_{\text{ray}}(\text{H}_2)]) = 1/([1.51 \times 10^{13}][1.047 \times 10^{-46}]) = 6 \times 10^{32} \text{ cm}. \quad (2.2.4.2)$$

Utilizing the exponential change in scattering along the Gaussian beam

$$I = I_0 e^{-z/l_{\text{ray}}}, \quad (2.2.4.3)$$

where I is the intensity of the scattering in photons per second at a distance z from the GB transmitter and I_0 is the initial intensity of the GB = $1.51 \times 10^{26} \text{ s}^{-1}$. The interaction volume, where the EM, HFGWs and the magnetic field interact to produce the PPF,

extends from $z = 10$ cm to $z = 40$ cm, so that the intensity difference between these two points (the scattering from the interaction volume) is $I(10) - I(40) = I_0 (e^{-10/ra} - e^{-40/ra}) \approx (1.51 \times 10^{26})(-1 + 10/6 \times 10^{32} + 1 - 40/6 \times 10^{32}) = 3 \times 10^{-7}$ photons per second scattered in the 30 cm long interaction volume, **which is negligible**.

8. With regard to diffraction elimination, the corners at **B, B', C** and **C'**, of Fig. (2.2.4b) would exhibit radii of curvature in excess of two wavelengths (6cm) and no diffraction of the GB should occur. At the relatively long wavelengths of the microwaves in the GB, small obstructions and corners could, however, be sources of diffraction. Because of that and in order to facilitate the installation (attachment) of the absorbing material, the radiuses of the corners are designed to be over three wavelengths (9 cm) in length (shown schematically in Fig. (2.2.4b)).

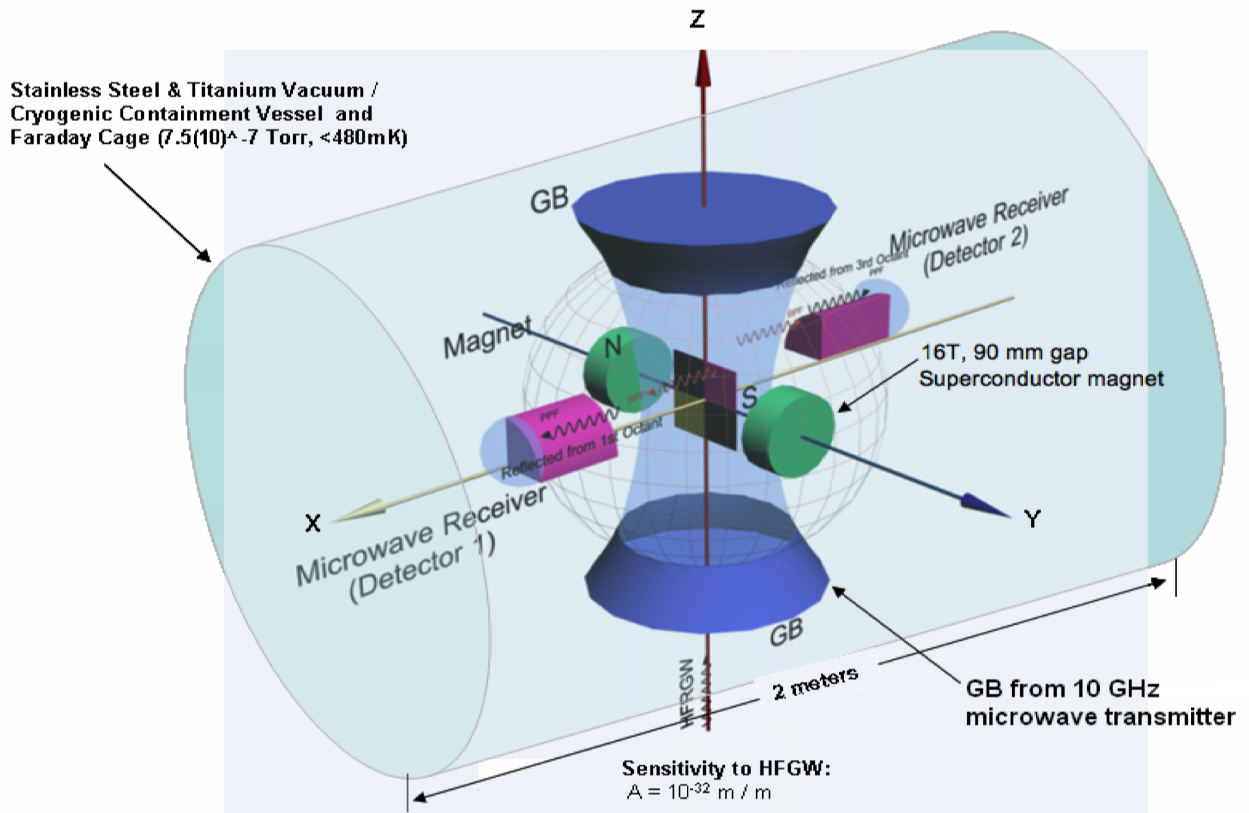

Figure 2.2.4a. Schematic of Li-Baker HFGW Detector (Peoples Republic of China Patent Number 0510055882.2)
<http://www.gravwave.com/docs/Chinese%20Detector%20Patent%2020081027.pdf>

In connection with HFGW detection it should be recognized that **only** the noise (not the signal or detection photons --PPF) is present when the magnetic field is turned off, so the

noise can be “labeled,” therefore the PPF signal can be isolated and distinguished from the effects of the Gaussian beam, enabling detection of the HFGW. A major noise-reduction concept for the HFGW detector involves microwave absorbers. Such absorbers are of two types: metamaterial or MM absorbers (Landy, et al., 2008) and the usual commercially available absorbers. In theory multiple layers of metamaterials could result a “perfect” absorber (two layers absorb noise to -45 db according to p.3 of Landy, et al., 2008), but in practice that might not be possible so a combination of MMs (sketched as dashed **blue lines** in Fig. 2.2.4b) backed up by the commercially available microwave absorbers would be desirable. As Landy, et al. (2008) state: “In this study, we are interested in achieving (absorption) in a single unit cell in the propagation direction. Thus, our MM structure was optimized to maximize the (absorbance) with the restriction of minimizing the thickness. If this constraint is relaxed, impedance matching is possible, and with multiple layers, a perfect (absorbance) can be achieved.” As to the commercially available microwave absorbers, there are several available that offer the required low reflectivity. For example ARC Technologies, Cummings Microwave, the ETS Lindgren Rantec Microwave Absorbers to mention only a few. The ETS Lindgren EHP-5PCL absorbing pyramids seem like a good choice. At normal incidence the typical reflectivity is down -45 db (guaranteed -40 db). The power for one 10 GHz photon per second is 6.626×10^{-24} W and if one can tolerate one thousandth of a photon per second for a series of back and forth reflections off the microwave absorbent walls of the detector as the stray radiation (BPF) ricochet in a zigzag path to the detector (shown in **red** in Fig. (2.2.4b)), then if the **stray radiation were 1000 watts** the total required db drop should be:

$$\text{Power db} = 10 \log_{10} (\text{power out}/\text{power in}) = 10 \log_{10} (6.626 \times 10^{-27}/1000) = -290 \text{ db} \quad (2.2.4.4)$$

so there should be no problem if there were $290/40 \approx 7$ reflections of the noise (BPF) off the pyramids without any other absorption required. Note that Eq. (2.2.4.4) provides the needed absorption of the BPF noise before reaching the detector(s) for a **full** 1000 watts of stray radiation. A possible better approach would be to remove the restriction of minimizing the MM thickness and incorporate them in the absorption process. Let us consider an absorption “mat” consisting of four MM layers, each layer a quarter wavelength from the next (in order to cancel any possible surface reflection) and provide a - 45 db -45 db - 45 db = -135 db absorption. Behind these MM layers would be a sheet of 10 GHz microwave pyramid absorbers providing a -40 db absorption before reflection back into the four MM layers. Thus the total absorption would be -135 db -40 db -135db = -310 db. The absorption mat would cover the containment vessel’s walls as in Figs. (2.2.4b) and (2.2.4c). These walls are configured to have a concave curvature facing the corners at **B, B’, C and C’** such that any off-axis waves from the Gaussian beam or GB (stray waves or rays of BPF that may not have been eliminated by the absorbers in the transmitter enclosure) would be absorbed. The lower, bulbous section of the transmitter enclosure would only have a layer of microwave pyramid absorbers that would absorb most of the side-lobe radiation. In this case heat conductors would transfer the heat produced by the GB side lobe’s absorption to a cooling system outside the main detector enclosure. The neck of the transmitter enclosure shown in Fig. (2.2.4d) would be covered with the absorption mat in order to effectively absorb any remaining side-lobe stray

radiation before entering the interaction volume in the main detector enclosure. The data sheets concerning the 10 GHz microwave pyramid absorbers are as follows:

EHP-3PCL Microwave Absorber PYRAMIDAL, HI-PERFORMANCE

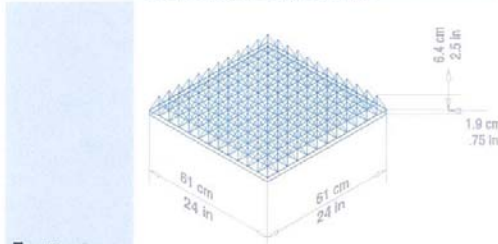

Features

- Numerically Optimized Design
- 200 V/m Power Handling Capability
- Fire Retardant

Physical Specifications

MODEL	EHP-3 PCL
Absorber Footprint	61 cm x 61 cm (24 in x 24 in)
Absorber Height	Overall 8.25 cm (3.25 in)
	Base 1.9 cm (.75 in)
	Pyramid 6.4 cm (2.5 in)
Pyramid Base Dimension	3.8 cm x 3.8 cm (1.5 in x 1.5 in)
Pyramids per Absorber	256
Weight (1 piece)	1 kg (2 lb)
Absorbers per Carton	22
Carton Dim. L x W x H	63.5 cm x 63.5 cm x 132 cm (25 in x 25 in x 52 in)

EHP-5PCL Microwave Absorber PYRAMIDAL, HI-PERFORMANCE

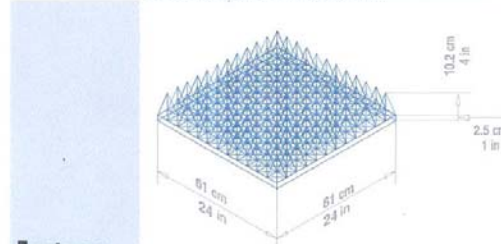

Features

- Numerically Optimized Design
- 200 V/m Power Handling Capability
- Fire Retardant

Physical Specifications

MODEL	EHP-5 PCL
Absorber Footprint	61 cm x 61 cm (24 in x 24 in)
Absorber Height	Overall 12.7 cm (5 in)
	Base 2.5 cm (1 in)
	Pyramid 10.2 cm (4 in)
Pyramid Base Dimension	5.1 cm x 5.1 cm (2 in x 2 in)
Pyramids per Absorber	144
Weight (1 piece)	1.6 kg (3.6 lb)
Absorbers per Carton	14
Carton Dim. L x W x H	63.5 cm x 63.5 cm x 132 cm (25 in x 25 in x 52 in)

Measured Reflections at Normal Incidence

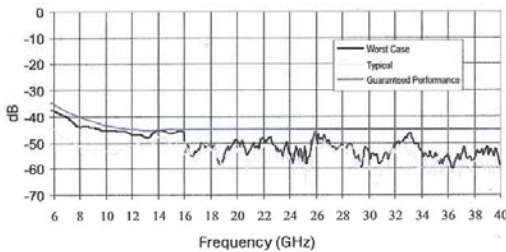

FREQUENCY/BAND	TYPICAL REFLECTIVITY	GUARANTEED REFLECTIVITY
4-8 GHz C-Band	-35 dB	-30 dB
8-12 GHz X-Band	-45 dB	-40 dB
12-18 GHz Ku-Band	<-45 dB	-45 dB
18-40 GHz K-Band	<-45 dB	-45 dB

Measured Reflections at Normal Incidence

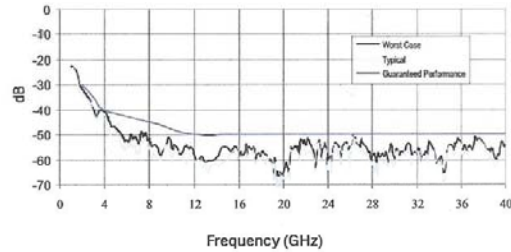

FREQUENCY/BAND	TYPICAL REFLECTIVITY	GUARANTEED REFLECTIVITY
2-4 GHz S-Band	-32 dB	-30 dB
4-8 GHz C-Band	-42 dB	-40 dB
8-12 GHz X-Band	<-50 dB	-45 dB
12-18 GHz Ku-Band	<-55 dB	-50 dB
18-40 GHz K-Band	<-50 dB	-50 dB

USA: Tel +1.512.531.6400 Fax +1.512.531.6500	FINLAND: Tel +358.2.8383.300 Fax +358.2.8651.233	UK: Tel +44.(0)1438.730700 Fax +44.(0)1438.730751	FRANCE: Tel +33.1.48.65.34.03 Fax +33.1.48.65.43.69	JAPAN: Tel +81.3.3813.7100 Fax +81.3.3813.8068	CHINA: Tel +8610.8275.5086 Fax +8610.8275.5537	ONLINE: Info@ets-lindgren.com www.ets-lindgren.com
---	---	--	--	---	---	---

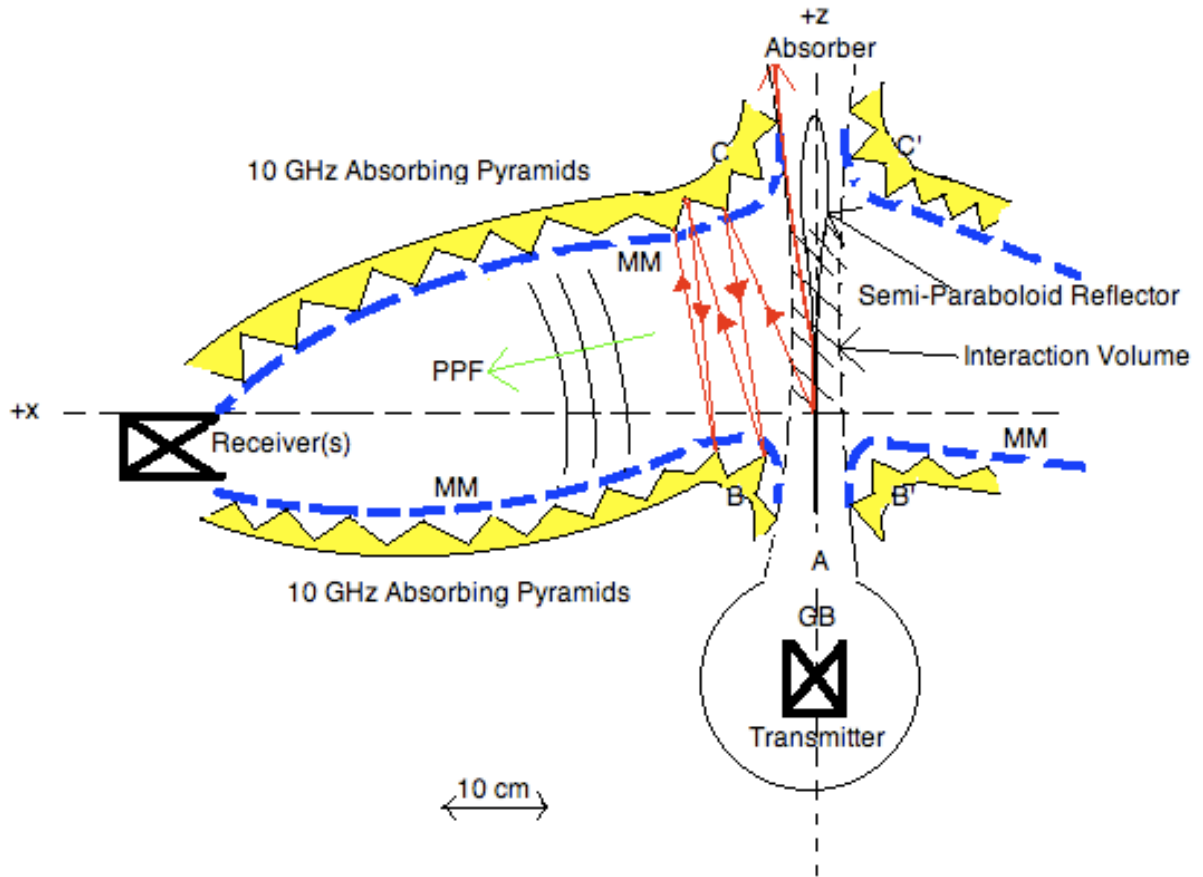

Figure 2.2.4b Side-view Schematic of the Li-Baker HFGW Detector Exhibiting Microwave Absorbent Walls.

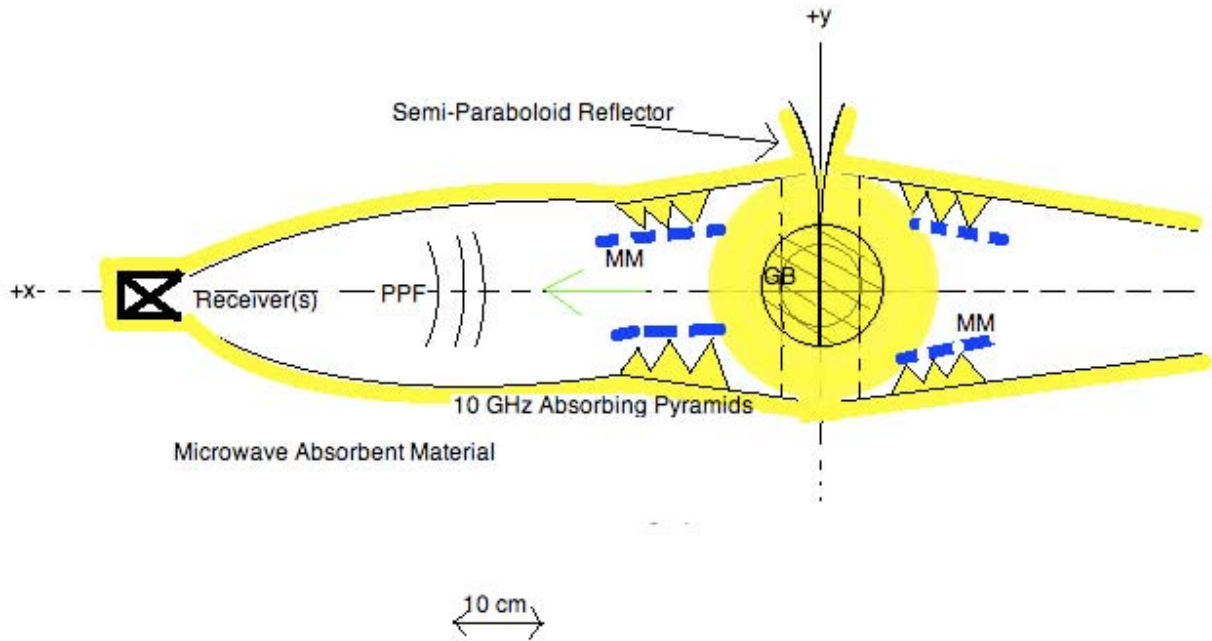

Figure 2.4.4b. Plan-view Schematic of the Li-Baker HFGW Detector Exhibiting Microwave Absorbent Walls.

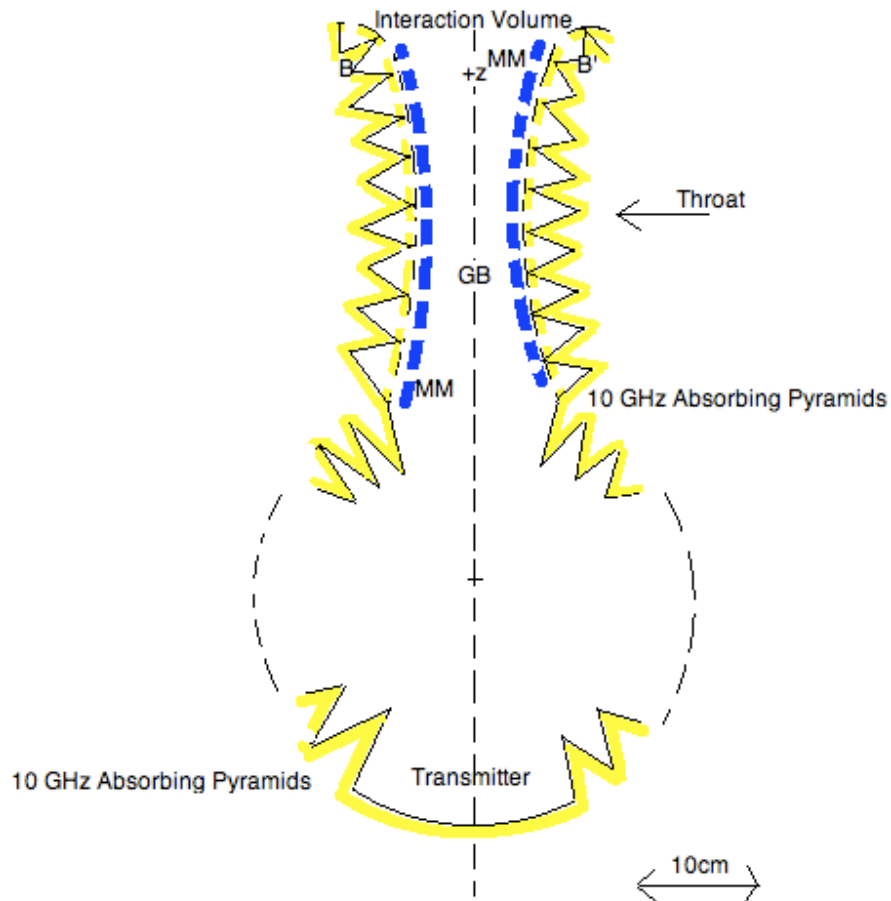

Figure 2.2.4c. Gaussian-Beam Transmitter Compartment (Patents Pending).

Here's how the Li-Baker HFGW detector works:

1. The perturbative photon flux (PPF), which signals the detection of a passing gravitational wave (GW), is generated when the two waves (EM and GW) have the same frequency, direction and suitable phase. This situation is termed “synchro-resonance.” These PPF detection photons are generated (in the presence of a magnetic field) as the EM wave propagates along its z -axis path, which is also the path of the GWs, as shown in Figs. (2.2.2), (2.2.4a) and (2.2.4b).
2. The magnetic field \mathbf{B} is in the y -direction. According to the Li effect, the PPF detection photon flux (also called the “Poynting Vector”) moves out along the x -axis in both directions.
3. The signal (the PPF) and the noise, or background photon flux (BPF) from the Gaussian beam have very different physical behaviors. The BPF (background noise photons) are from the synchro-resonant EM Gaussian beam and move in the z -

direction, whereas the PPF (signal photons) move out in the x-direction along the x-axis and only occur when the magnet is on.

4 The PPF signal can be intercepted by microwave-absorbent shielded microwave receivers located on the x-axis (isolated from the synchro-resonance Gaussian EM field, which is along the z-axis).

5. The absorption is by means of off-the-shelf -40 db microwave pyramid reflectors/absorbers described in the proceeding data sheets and by layers of MM absorbers. In addition, isolation is further improved by cooling the microwave receiver apparatus to reduce thermal noise background to a negligible amount. In order to achieve a larger field of view and account for any curvature in the magnetic field, an array of microwave receivers having, for example, 6cm by 6cm horns (two microwave wavelengths or $2\lambda_e$ on a side) could be installed at $x = \pm 100$ cm (arrayed in planes parallel to the y-z plane).

3.0 OPERATIONAL CONCERNS

3.1 Link Budget

3.1.1 Signal-to-Noise Ratio

Signal-to-noise ratio (SNR) is an important figure of merit in communication systems because it is an indicator of whether or not a transmitted signal will be useful upon arrival at its destination, the receiver. Without *processing gain* an $SNR > 1$ will be required to maintain a link budget. On the transmitter's end, the signal to noise is determined by the useful signal that is produced by the transmitter after it is already in its transmission mode, such as the GW power at the output of the GW generator antenna, divided by the RSS (*Root Sum Square*) of the uncorrelated noise sources referred to the same spot in the signal chain, i.e. output referred *noise equivalent power* (NEP). This signal to noise ratio is represented by the left hand column in Fig. 3.1a. A rather unique feature of the Li-Baker HFGW Detector is that almost all the noise sources are present when the magnetic field is "off" and there is no signal or detection photons present. With the magnetic field "on" there is the noise plus the signal. Thus one can distinguish between signal and noise! In principal one could subtract the noise (with the magnet "off") from the signal plus "noise" with the magnet "on" and obtain the signal alone. More detail is presented on this feature below. The components of the transmitter's NEP may be sorted by the source of the noise. First, before the signal is converted to GW it is in the realm of EM or photon radiation. Photons themselves make noise, and this component goes as the square root of the total number of photons. Then there is thermal noise, that is, the photons generated by blackbody radiation of the transmitter components themselves. Other electronic and semiconductor components providing the source signal generate their own photon noise due to carrier activity. All these noise sources are carried along with the original EM signal and may be converted just as faithfully as if they were signals should they fall within the transmission bandwidth. All of this is just for the EM noise component. The generation process itself may also be a

source of noise, and will vary widely depending upon the generator method used. For example, the generation process noise created in the FBAR generator would be significantly different than that created in a tuned resonant IR-excited toroidal cavity or by laser HFGW generation, etc. This of course would be an important consideration in selecting a generator type.

Finally, it is expected that there are a variety of GW noise sources. Background sources from space are predicted, but in low levels (A around 10^{-30} m/m), across the entire HFGW frequency spectrum. Also, in a GW generator situation, parasitic vibrations may also have quadrupole moments, such as the walls of a generation cavity for instance, or an unwanted vibration within a slab of semi conductors, and although very unlikely, these could also generate HFGW noise. Then there is link loss to contend with. While it is expected that the attenuation of GW due to absorption and scatter will be quite low, geometry alone will dictate that a spherically uniform radiating source at a distance R will fall off as $1/R^2$. This link loss will affect both the transmitted signal and the transmitted noise. In the receiver most of these same noise sources are duplicated in reverse, as shown on the right hand column of Fig. 3.1a. Referring power now to the input, there will be a received power and the received power includes propagated transmitter noise. Added to this will be GW noise admitted or created by the receiver that was not created at the transmitter (primarily any non-absorbed GB spillover), also GW to EM conversion noise, and EM receiver noise of the same types as outlined for transmitters. When all these noise components are referred the input of the receiver, the total NEP, which is the RSS of all the noise components, must be less than the signal present at the input of the receiver to qualify as a useful link.

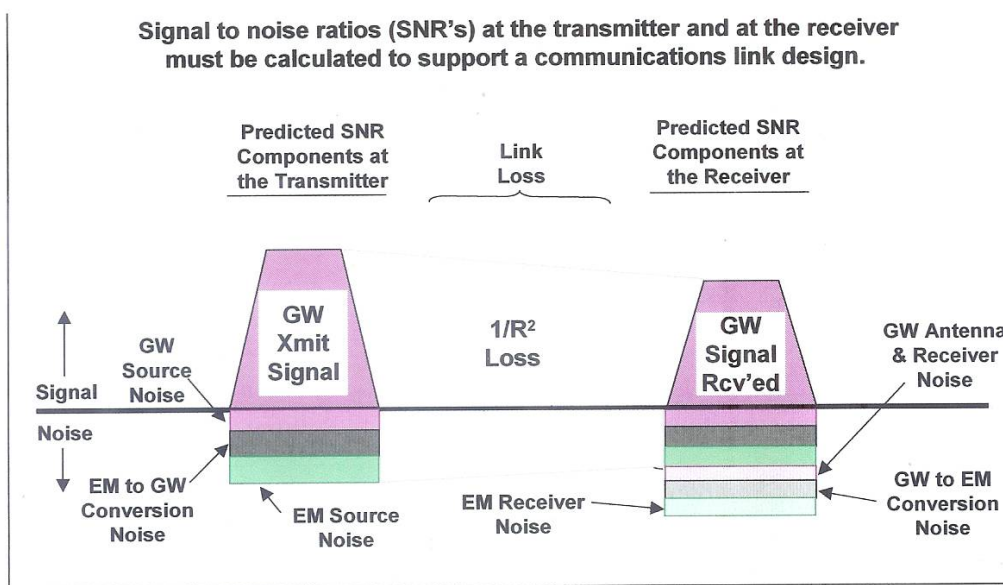

Figure 3.1a. Conceptual SNR Fill Factors: Signal and Noise Components

There is the complicating factor in that one can “label” the noise in the link by periodically turning off the magnetic field in the Li-Baker detector during some sample time. The signal would disappear, but all the noise sources would still be present. Not only is this a good diagnostic tool to reduce noise, but it also might allow for a *signal to noise ratio less than unity*. Consider a simplified case of a square wave energizing the magnet, with the magnet alternatively “off” and “on.” With the transmitter’s magnetic field “off” (no signal) one could average (integrate) the noise over some time interval (sample time), “store it,” and with the magnetic field “on” (signal and noise both present) one could integrate and “store” and subtract the two and obtain the signal. Of course the noise is not a constant, but exhibits a stochastic or random component. In order to obtain the best estimate of the signal one would, therefore, need to filter the difference, possibly using a Kalman filter (pp. 376-387 of Baker (1967)) in order to obtain the signal even with the noise exceeding the signal. As Stephenson points out “...signal to noise, signal to clutter, and signal to background ...” might all be improved by such filtering

A few comments are in order regarding the “ Q -factor” of the receiver. (Q characterizes a resonator's bandwidth relative to its center frequency. Higher Q indicates a lower rate of energy loss relative to the stored energy of the oscillator; the oscillations die out more slowly. For example, a resonance chamber exhibits a high Q if there are a large number of reverberations or “ricochets” of a signal: in it.) One way to increase Q is to narrow bandwidth. However, this has limited value. At some point, shrinking the bandwidth will shrink the signal received as quickly as the noise received, and some receiver noise components remain constant, resulting in a net drop in SNR. Another way to increase Q is to arbitrarily increase sample times of the signal. This technique will, relatively speaking, shrink receiver end noise components as referred to the input of the receiver, but it will not have any impact of the noise generated at the transmitter. Therefore in this case the SNR will approach a constant. However, both of these approaches for improving sensitivity will have an adverse effect on the information capacity of the channel, which is important for a communication application.

3.1.2 Link Budget Considerations

Now consider the signal side of the communication challenge. The central question is how do we close the link? That is, how much signal is necessary at the input of a communication channel to have a useful signal at the other end? These questions may be answered, qualitatively in this case, by considering the terms of the expression in Fig. 3.1b. In general, an EM signal S_i will be used to actuate some type of GW generation device, and this device will have a conversion efficiency of μ_{eg} , which represents the ratio of power of the EM input signal to power of the GW signal generated. Not all of the GW generated will be constructively used to radiate in the desired direction - some of the GW power will be lost to destructive interference, and some will not be radiated through the antenna aperture for example the double-helix transmitter shown in Fig. (2.3.1c). Thus the transmitter will have a less than unity radiated power efficiency, R_x .

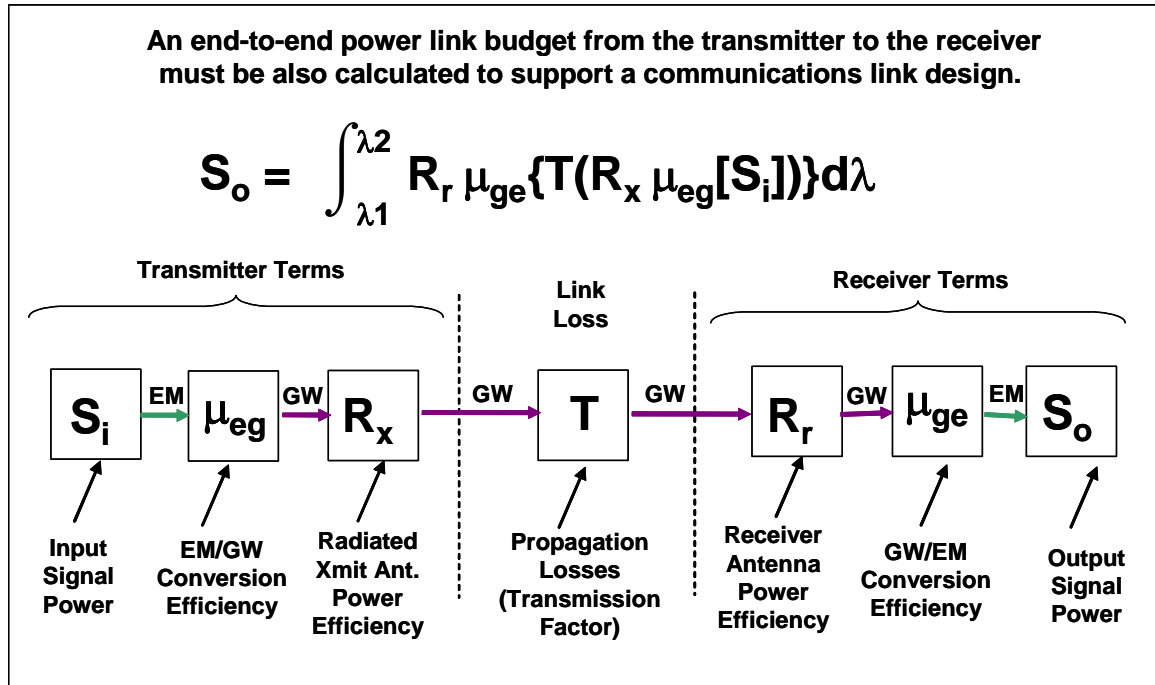

Figure 3.1b. A Block Diagram of a Typical Link Budget

Then there will be propagation link loss, or transmission loss, T , which will be the antenna pattern integrated across the solid angle of the receiver antenna aperture as seen from the source. The receiver may have an GW antenna that aids in focusing an otherwise wider solid angle into a narrower detection aperture, and if this is true, then there will be an efficiency associated with this receiver antenna, designated here as R_r . Since the HFGW beam designed is narrow (e.g., 10^{-4} radians) this effect will be maximized.

At the receiver's detector, there is another conversion factor to account for, the conversion efficiency of GW signal power to EM signal power μ_{ge} , which would be much less than unity, except that the Q factor enters the equation as a component of μ_{ge} . Of course Q may also impact the bandwidth range over which the signal is collected. There is also a hidden integral here which occurs over the sample time, which is understood.

All of these terms will have to be defined and well understood before a communication system can be successfully designed. Many of these parameters have been predicted for the components reviewed in prior sections; however, they will not be verified until a successful proof-of concept experiment (generator → detector or "Bell-Watson test") can be performed.

3.2 Frequency and Timing Standard (FTS)

The first application of HFGW, which exhibit bandwidths of a few Hz, would be to the distribution of Frequency Time Standard data in order to assist otherwise conventional communications equipment. A typical near-Earth distribution system could conceivably result in a number and configuration of the ground stations, shown in Fig. 3.2 a where their latitude and longitude are given in parentheses.

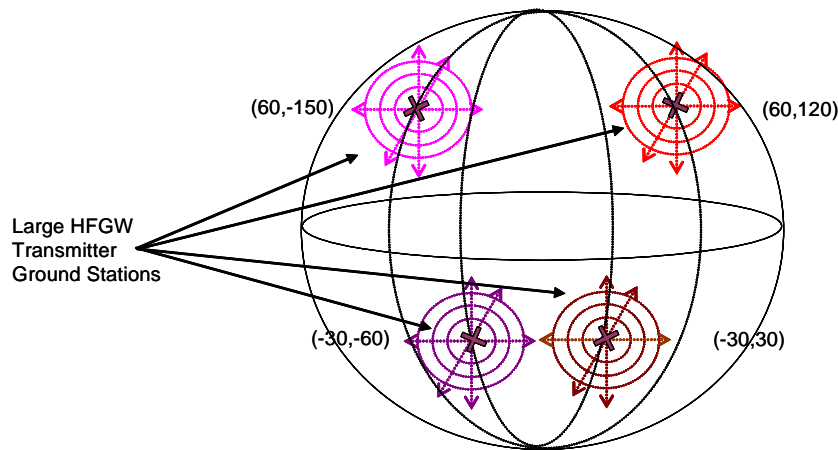

Figure 3.2a. A Proposed Near Earth Distribution of Frequency Time Standard.

The large transmitter ground stations would provide the signals used as both the *frequency and time standards* (FTS). All FTS ground stations would be synchronized such that they emit signals exactly in phase with each other, all tied to a common frequency time source, such as the US Naval Observatory. Each station would use a different frequency such that the *remote terminal* (RT) user set could easily differentiate signals, and any phase or time difference observed would be due to either the relative position of the remote terminal with respect to each ground station, or the relative velocity of the remote terminal with respect to each ground station. Each ground station would transmit both a *carrier wave* (CW) signal for a frequency reference and a *periodic pulse signal* (PPS) for a time reference. At least 3 ground stations would be needed for self-triangulation by the remote terminals, at least 4 with redundancy. HFGWs will propagate through the Earth with little modification, but very slight HFGW phase modification may be observed in surveillance applications (Baker, 2007.)

The counterpart to the fixed ground infrastructure would be the remote terminal side or user side of the FTS infrastructure. Each remote terminal would need to be equipped with a small HFGW receiver, which could pickup all 3 or 4 ground stations simultaneously. The arrival times of the received PPS signals could be compared via *time difference of arrival*, or TDOA, and used to develop a position estimate. The CW signal phases could be compared to determine the Doppler velocity of the remote terminal with respect to an *Earth Centered Inertial* (ECI) coordinate system. Thus, the HFGW FTS system could be used as a navigational aid, akin to the GPS system. This end of the infrastructure would be receive only and could therefore be a very low power device. Therefore mobile devices, such as portable remote space borne terminals could be typical users of such a

navigational service. An example is depicted in Fig. 3,2b.

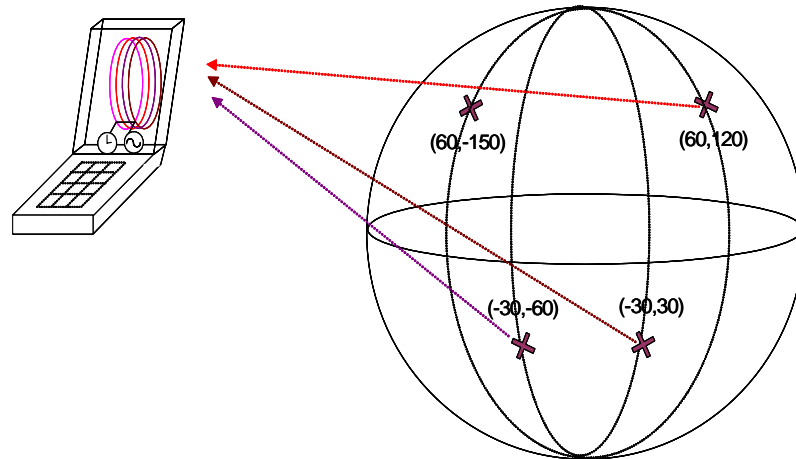

Figure 3.2b. HFGW Supplemented Remote Terminal Design.

The navigational sensitivity of the HFGW receiver would depend on the frequencies used in the HFGW FTS system, as the received CW HFGW signal would act as the remote terminal's "built-in" frequency standard, replacing the need for internal crystal oscillators or Cesium or Rubidium standards. An HFGW FTS carrier wave with a frequency of 300 GHz with a wavelength of 1mm would result in 3 pico-second type time accuracy. The use of TDOA with these accuracies would allow for arbitrarily small navigational errors.

3.2.1 Improvements Accruing from a HFGW Time Standard

The cost of the FTS infrastructure must be more than balanced by the benefit resulting from that infrastructure if the cost is to be justified. Given that the GPS already provides adequate navigation services for most applications, navigational benefits alone would not justify the cost of an HFGW FTS system. However, in the case of a universal HFGW FTS, there are additional benefits associated with applying the frequency and time standards to standard telecommunications problems. The universal nature of the HFGW frequency and time standards are especially helpful. The following telecommunication benefits of an HFGW FTS system will be described in this section: improvement in acquisition time from search space improvements, improvements in modulation and coding efficiency from phase noise improvements, and improvements in bandwidth efficiency from frequency noise improvements.

3.2.2 Search Space Improvement Accruing from HFGW FTS

The following points are relevant with respect to the universal use of HFGW FTS among all remote terminals (including for instance cell phone handsets and their associated cellular towers):

- During signal acquisition the receiving terminal must perform a search of the search space of frequency, phase, and code to acquire the transmitting terminal signal.

- If there is less noise in these parameters the search space is reduced, speeding acquisition.
- Ultra-fast acquisition allows more efficient TDMA, or Time Domain Multiple Access style operations, such as transmit on demand, that use bandwidth more efficiently.

The smaller resultant search space is depicted graphically in Fig. 3.2a :

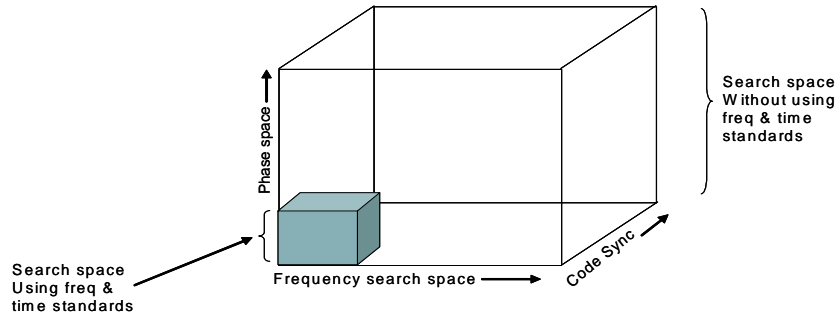

Figure 3..2a Acquisition Search Space Improvement Accruing from HFGW FTS.

An equation for acquisition search space time is presented in Eq. (3.2.1)

$$T_{acq} = N_{phase} \times N_{freq} \times N_{code} \times (t_a) \quad (3.2.1)$$

where N_{phase} = number of phase space cases to check for acquisition,
 N_{freq} = number of frequency cases to check for acquisition,
 N_{code} = number of code sync possibilities to check and
 t_a = acquisition test time, per test case.

In a typical example, if 30 MHz chipping is used with a 5 μ sec error, there will be 150 code sync possibilities to check. If we also use a case where a frequency error of 1Hz within the acquisition window would cause a missed acquisition, and the worst case frequency error is 150Hz, then the number of frequencies that must be checked is also 150. Finally, we must check each possible phase possibility, say 16 different options for 16-PSK. PSK stands for *Phase Shift Keying* and is the encoding of data bits using incremental phase modulation. For a 5 μ sec acquire test time, the result is $T_{acq} = 150 \times 150 \times 16 \times (5 \mu\text{sec}) = 1.8$ seconds acquisition time.

However, with effectively perfect knowledge of time, frequency, and hence also phase, there will only be one case to check, so result is $T_{acq} = 1 \times 1 \times 1 \times (5 \mu\text{sec}) = 5 \mu\text{sec}$ acquisition time. This is essentially instantaneous for applications such as TCP/IP or VoIP. This will favorably impact the overall TDMA efficiency in that it speeds the claiming process to the point where an "always on" link can be replaced by a "link on demand." This is a savings of 25% to 50% in channel usage for VoIP and TCP/IP sessions over "always on".

3.2.3 The Impact of Phase Noise Improvements on Phase Shift Encoding

The use of a universal HFGW FTS would also benefit the relative phase noise of all terminals, allowing for finer phase encoding. Phase noise limits the type of modulation and manner of encoding that can be performed in phase space, commonly used for over the air telecommunication systems. An HFGW FTS system could reduce phase noise by providing a frequency reference with outstanding stability. For example, moving from QPSK to 8PSK or 16-PSK improves bandwidth efficiency by a factor of 2 to 4. The phase space improvement is summarized in Fig. 3.2b

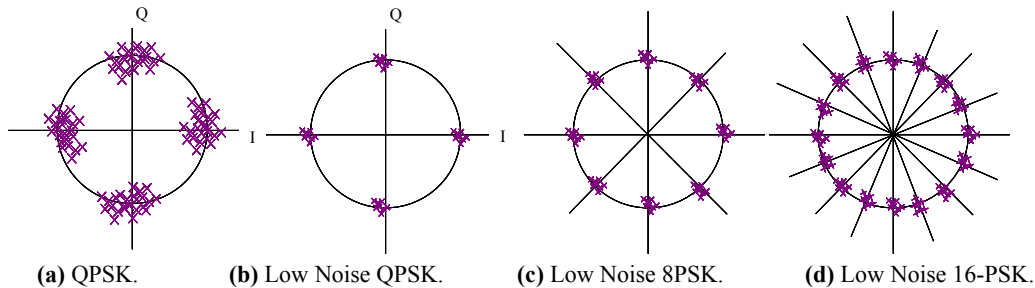

Figure 3.2b The Impact of Phase Noise Improvements on Phase Shift Encoding.

In the example of Fig. 3.2b nominal performance allows only QPSK, but improved phase noise would allow higher density phase encoding. Data rate will scale linearly with encoding efficiency as shown in Eq. (3.2.2):

$$\text{Data Rate} = (\text{BW}/2) \times (\text{Coding Efficiency}) \times (\text{FEC Rate}) / (\text{PN Spreading Factor}) \quad (3.2.2)$$

Coding efficiency will be a factor of 2 better when moving from QPSK to 8PSK, or a factor of 4 better when moving from QPSK to 16-PSK. This will translate directly into a linear increase in the allowable data rate that a given bandwidth can support. Put another way, a universal frequency time standard could quadruple over the air bandwidth efficiencies just by improving phase noise alone. Phase noise improvements would be limited only by the slight variations induced in the HFGW signal passing through the earth as described in Baker (2007).

3.2.4 The Impact of Frequency Noise Improvements on FDMA and FHSS

The very low noise frequency standard that would be supplied by an HFGW FTS system would allow for much more efficient use of reserved frequency bandwidth. Frequency noise limits the type of modulation and manner of encoding that can be performed in frequency space, such as *Frequency Division Multiple Access* (FDMA) or *Frequency Hopping Spread Spectrum* (FHSS). HFGW can reduce frequency noise by providing a frequency reference with outstanding stability. For example, guard bands can be shrunk in FDMA, and frequency slices can be smaller and more stable in FHSS.

A frequency space representation of the FDMA and FHSS noise improvements are depicted in Fig. 3.2c:

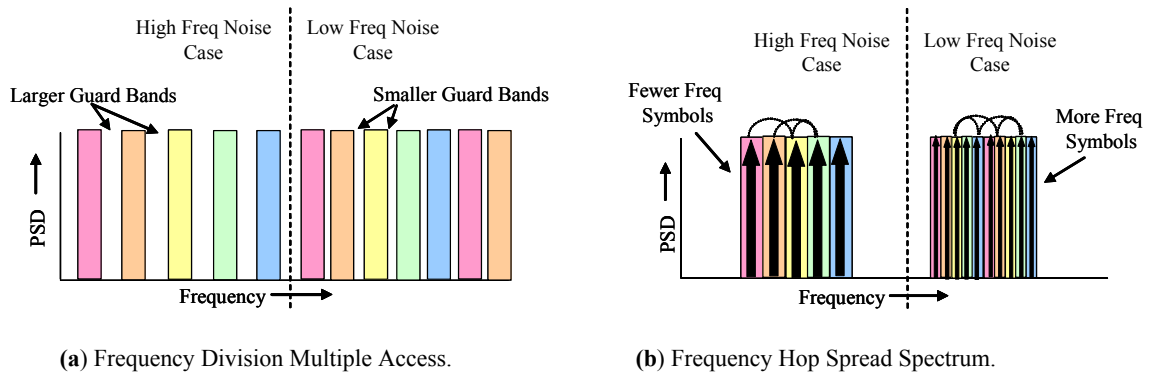

Figure 3.2c. The Impact of Frequency Noise Improvements on FDMA and FHSS.

Efficiencies in guard-band structure can be defined as in Eq. (3.2.3).

$$\text{Guard band BW Efficiency} = (\text{Total Bandwidth} - \{\text{Sum of Guard BW}\}) / \text{Total Bandwidth} \quad (3.2.3)$$

Guard bands often consume 30% to 50% of assigned frequency space. While guard bands would still be required to allow for the side lobes of signals, the frequency error component would be eliminated. Similar efficiencies may be gained in the FHSS approach. A better knowledge of absolute frequency allows better frequency coding efficiencies, as seen in Eq. (3.2.2) and depicted in Fig. 3.2c.

3.3 Possible Future Upgrades to the FTS Devices

Per the 9Feb09 issue of *New Scientist*, (#2694 – see reference link below in 3.3.1), optical lattice clocks are under development that will lead to a dramatic improvement over the current standard Cesium atomic oscillation clocks that now provide frequency time standard references. Optical lattice clocks vibrate at optical frequencies rather than microwave frequencies, with the reference frequency mixed down via frequency combs to allow measurements back down in the microwave regime. Strontium lattice clock are already operating with measurement precisions of 1 part in 10^{16} , and theoretical performance approaches 1 part in 10^{18} . At this precision one could measure the time delay caused by changing one centimeter in height in the Earth’s gravitational field.

3.3.1 Propagating signals from optical lattice clocks for timing

The 1 part in 10^{18} measurement precision of optical lattice clocks will be affected by general relativity effects, in other words propagation delays due to gravitational field gradients will be readily measurable. "It will make us think a little harder about what we really mean by time," says Dan Kleppner of MIT. [Ref link: <http://www.newscientist.com/article/mg20126941.900-super-clocks-more-accurate-than-time-itself.html?full=true>] In effect, measuring the propagation delays at this level allows very fine measurement of the “geoids,” or surfaces of constant gravity, surrounding planets and inhabiting interplanetary and interstellar space. The delay experienced by RF

waves could therefore be precisely compared with the propagation delay experienced by gravitational waves, which are not as strongly affected by the presence of mass. Such a differential propagation delay comparison (between RF & GW) could *lead to an important new technology in the mapping of geoids*, which could for instance be applied to the problem of mapping the positions of the Lagrangian points, which vary slightly over time.

3.3.2 In navigating and mapping interplanetary geoids

The importance of locating and navigating to Lagrangian points is well established [Ref link: <http://www.newscientist.com/article/mg20126962.000-do-gravity-holes-harbour-planetary-assassins.html>]. See Fig. 3.3.2a for a depiction of the Earth's Lagrangian points and their uses.

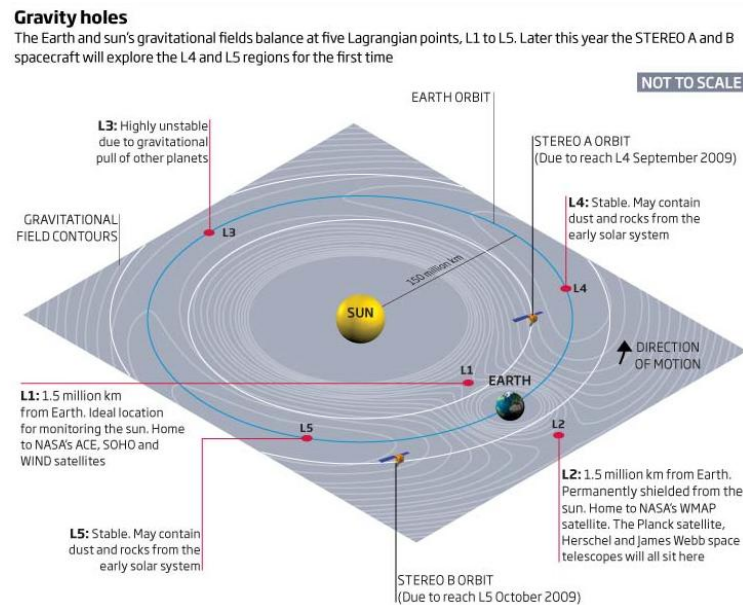

Figure 3.3.2a The Earth's Associated Lagrangian Points [New Scientist, 9Feb09 and Baker (1967), p.128, Fig. 2.2]

L1 is an ideal location for solar monitoring, whereas **L2** is permanently shielded from ion of differential propagation delay comparisons between RF and GW.

4.0 FUTURE POTENTIAL

4.1 Developmental Roadmap

A development roadmap is suggested here for the application of High Frequency Gravitational Waves (HFGWs) in the field of communications. The development roadmap should be two fold:

- 1) Theoretical work should continue on HFGW transmitters (generators) and receivers (detectors)
- 2) Experimental devices should be built and tested in the laboratory and then transitioned over to a practical communications system (for a *Work Statement* of such an effort please see **APPENDIX A**).

A suggested developmental roadmap schedule and phasing timeline is included as Fig. (4.1). Theoretical research is always an ongoing enterprise, but it is especially important to encourage work in the development of experimental approaches aimed at demonstrating laboratory generation and sensing of gravitational waves for the next few years. This is the kind of academic work that is best done in a research university or private research laboratory setting, at least for the next ten years or so, until two or more laboratory experiments can verify laboratory generation. Without early confirmation the technology will not gain widespread acceptance and move forward.

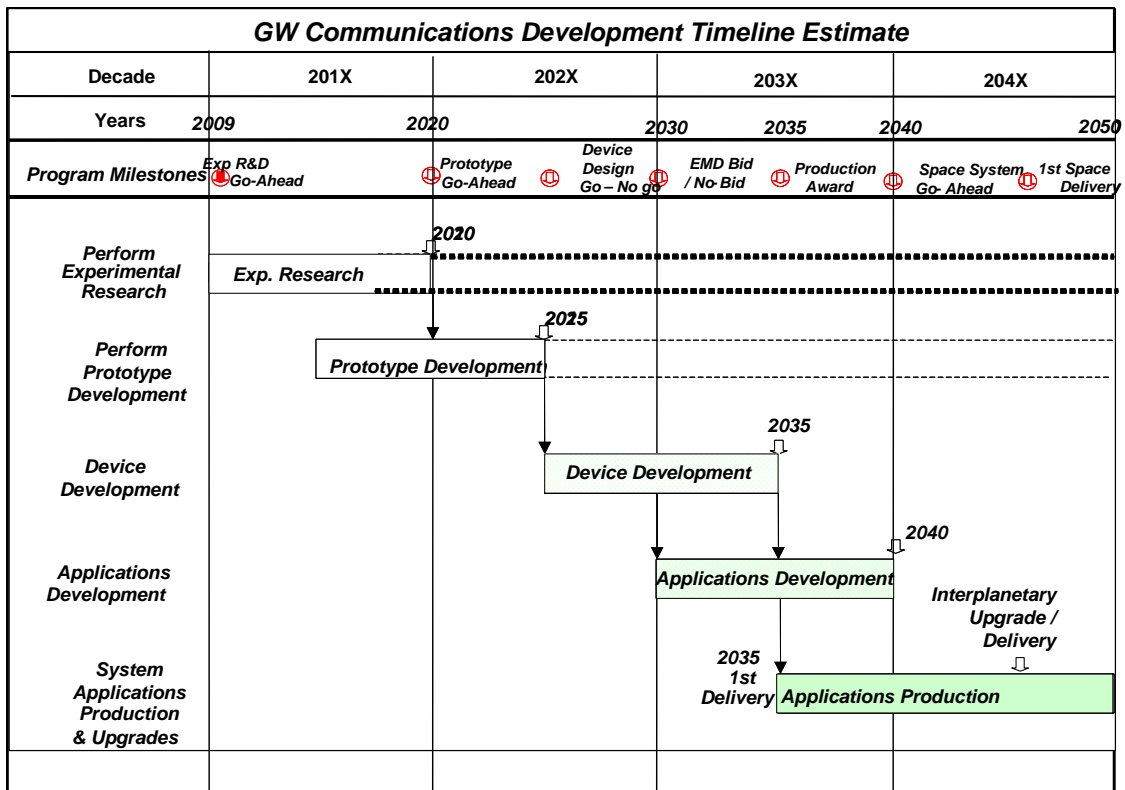

Figure 4.1. HFGW Communications Space Application Development Roadmap, Estimated Timeline

The most benefit would come from a coordinated effort spread over a number of different universities and private laboratories. Wherever possible, pre-existing assets should be utilized to stretch funding as far as possible. For example, if synchrotron light is needed to verify the Li-effect, then a survey of existing national synchrotron light facilities should be part of the funded effort to find an appropriate host facility. The funding activity, i.e. the National Science Foundation, would have the overall responsibility to coordinate this activity in an ongoing manner, through proposal review, contract awards, and progress

reviews, and the approach should be flexible enough to allow the redirection of funding should a particularly promising new technology or invention move to the forefront.

Assuming that positive laboratory results can be achieved and peer reviewed in a 10 to 12 year timeframe, the next step would call for a period of prototype development, in which the device physics and engineering needed to support the technology could be matured. As prototypes show promise they could be transitioned to device development, the first time that industry would likely enter the field. Once the individual devices required to support GW communication technology are in place, e.g. GW generators (transmitters) and GW sensors (detectors or receivers), at that point it will be possible to begin full scale development of systems applications. This is a conservative timeline, based on scaling from the development of previous technologies. If breakthroughs materialize, or if the pace of technological development quickens, or if there is a perceived need for early implementation, then progress may certainly occur more quickly than this.

4.2 HFGW Communications Predictions to 2050

In what follows, with an eye to the future, extrapolations are made concerning the development of a HFGW communications technology into the far future, e.g., 2050 and beyond. It is difficult to predict even ten years in advance to the time when we expect to have the results of the proof-of-concept test (or the so-called “Bell-Watson” experiment) are available and the immediate applications to HFGW communications completed. Speculation beyond that time will be contingent upon advanced development of FBAR crystals, new microwave absorbers, applications of nanotechnology, etc. or even entirely new approaches such as those proposed by Giorgio Fontana, Valentin Rudenko, Raymond Chiao, R. Clive Woods, Gary Stephenson, et al. No doubt the Li-Baker detector performance can also be greatly improved with stronger magnetic fields, more intense EM Gaussian beams, and better microwave absorbent baffles as well as new detector designs yet to be developed possibly based upon theories developed at *Birmingham University*, *INFN Genoa* and *The National Astronomical Observatory of Japan*. Optimum designs of communication channels, bands and modulation are also be anticipated. Many of these advanced concepts were discussed at the 3rd HFGW Workshop in Huntsville last February (2009). Nanotechnology advances will allow for the fabrication of smaller and smaller HFGW transceivers having millimeter dimensions and milliwatt power requirements by 2050. “Radio ID” or rather “HFGW ID” nanochip tags may be ubiquitous. “Soft” airline tickets and bag tags, sub-dermal HFGW ID chip implants (since no harmful GW radiation, effects) Gravitational-wave transmissions would also have the advantage of being able to pierce the protective plasma shielding that may in the future be routinely used to protect the crew aboard manned vessels, i.e. communications through artificial magnetospherics, a technological limit of RF communications.

4.3 Interplanetary Navigation and Geoid Mapping to 2050

While there is no doubt that stellar tracking will remain the primary source of navigation for space missions in the foreseeable future, as introduced in section 3.3.2, HFGW may

also prove useful in conjunction with RF in providing a navigation aid for interplanetary missions (with no planetary shielding) by mapping geoids in interplanetary space via long baseline navigation. For instance, if there were one GW source on Earth, and one GW source on the Moon, such a pair of GW sources would provide relative beacons for missions to Mars that could serve multiple roles as navigation beacons, communication relays, and in conjunction with RF signals, maps geoids via relative time difference of arrival signals. *Very Long Baseline Navigation* (VLBN) could be achieved by placing a source on Earth and one GW source on Mars for a baseline that would most often be very widely spread with respect to the outer planets, for outer planetary missions. See Figs. 4.3a – 4.3c for a number of different navigation beacon pair options. Thus the High-Frequency Relic Gravitational Waves (HFRGWs) could not only serve as a means for validating ultra-high sensitivity HFGW detectors such as the Li-Baker, but also might be a reference for terrestrial and extraterrestrial navigation and a possible background illuminating radiation source for HFGW surveillance.

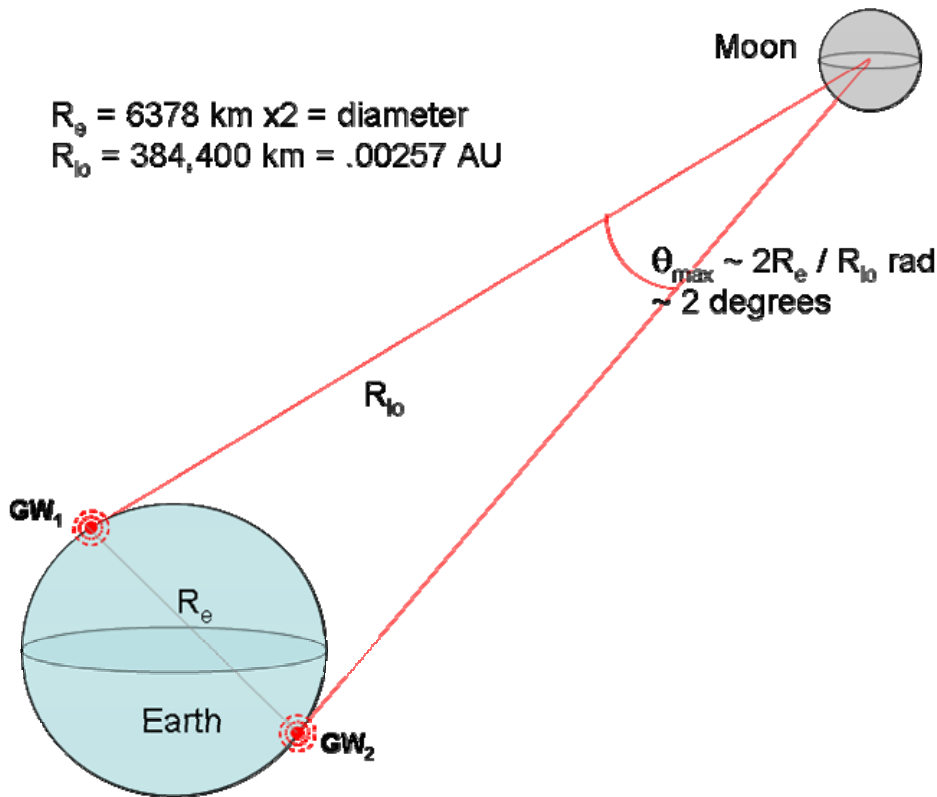

Figure 4.3a. A GW pair on Earth as used by a Lunar Mission

Lunar Librations (Klemperer and Baker, 1957) could be directly measured by HFGW stations on opposite sides of the Moon. A discussion of lunar trajectory navigation can be found on pp. 342-395 of Baker (1967). In particular the utilization of Kalman Filtering or sequential processing of observational data would find added precision through the acquisition of HFGW navigation data such as VLBN reception. This same comment

holds true for interplanetary trajectory navigation (discussed on pp. 396-434 of Baker (1967)).

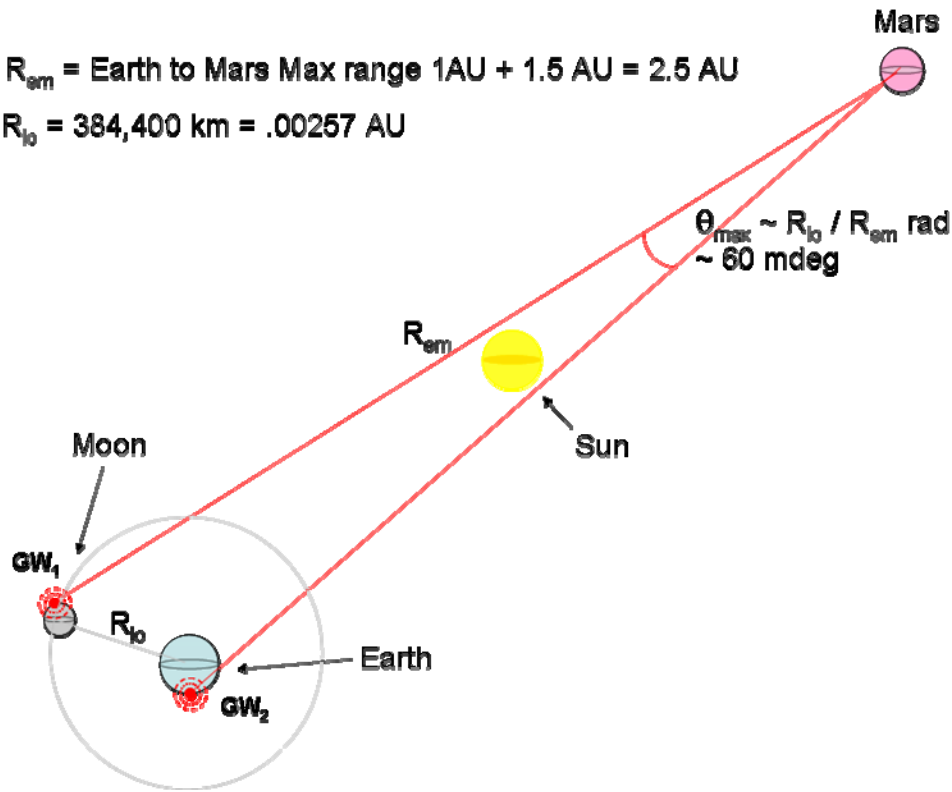

Figure 4.3-1b, A GW pair on Earth and on the Moon, as used by a Mission to Mars

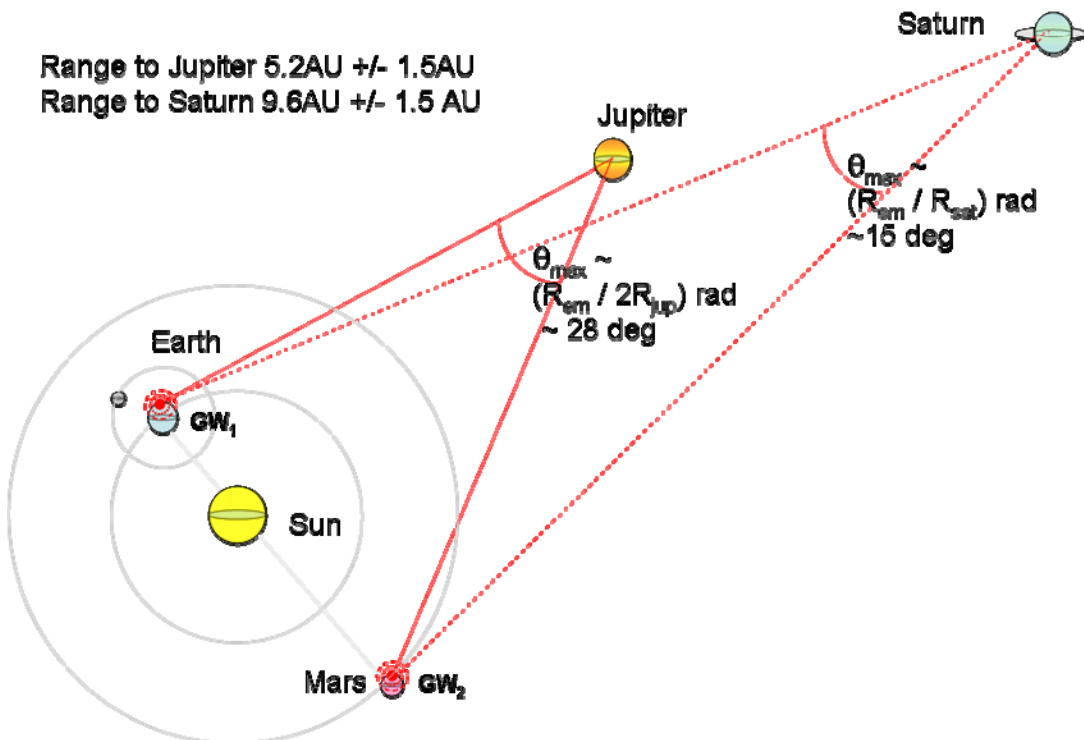

Figure 4.3c. A GW pair on Earth and on Mars for an Outer Planetary Reference

4.4 Other Possible HFGW Applications

The most stunning advances in HFGW applications will probably not be in communications, but in the remotely HFGW-generated nuclear fusion, HFGW propulsion (or remote displacement of objects) and HFGW surveillance. If an ultra-high-intensity HFGW flux impinges on a nucleus, it is possible that it could initiate nuclear fusion at a remote location, or mass disruption. Also it may be possible to create radioactive waste-free nuclear reactions and energy reactions (Fontana and Baker, 2007). As they suggest: “At high amplitudes, GR (*Gravitational Radiation*) is nonlinear, thus we might expect a departure from geometric optics. Fortunately, the problem has been already theoretically examined and the resulting effects are found to be advantageous. Nonlinearity improves the focusing process and metric strain, h , goes to one in finite time, producing a singularity “regardless” of the starting, non-focused amplitude of the impinging gravitational wave (Corkill and Stewart, 1983; Ferrari, 1988a; Ferrari 1988b; Ferrari, Pendenza and Veneziano, 1988; Veneziano, 1987; Szekeres, 1992). The effect of a $\Delta h = 0.995$ pulse of HFGWs on the couple formed by a deuterium nucleus and its electron is the reduction of their relative distance by a factor of 200. If this distance reduction is effective for a few picoseconds, then the two nuclei of a deuterium molecule can fuse and give a He atom plus energy, which is the usual nuclear-fusion process in a star.”

HFGWs could theoretically be used for propulsion and control of the motion of objects such as missiles, missile warheads, anti-missiles, spacecraft, and asteroids, and remote control of clouds of hazardous vapors. Gravitational field changes by one or more HFGW generators could urge a spacecraft in a given direction, causing a lower static gravitational field in front of a vehicle (it “falls” forward) and a higher one behind (providing a “push”). The concept is that the mass essentially “rolls” down a “hill” produced by the static g-field; that is, potential energy increase of a mass is provided by the energetic HFGWs. The magnitude of the static g-field is proportional to the square of the HFGW frequency (Landau and Lifshitz, 1975, section 108, page 349). Specifically:

“Since it has definite energy, the gravitational wave is itself is the source of some additional gravitational field [static g-field]. Like the energy producing it, this field is a second-order effect in the h_{ik} . But in the case of high-frequency gravitational waves the effect is significantly strengthened: the fact that the pseudotensor t^{ik} is quadratic in the derivatives of the h_{ik} introduces the large factor λ^{-2} . In such a case we may say that the wave itself produces the background field [static g-field] on which it propagates. This [static g] field is conveniently treated by carrying out the averaging described above over regions of four-space with dimensions large compared to λ . Such an averaging smooths out the short-wave “ripple” and leaves the slowly varying background metric (static g-field).” (Brackets and underline added for clarity and emphasis.) Such an application must also await the future development of very high-intensity HFGW generators.

A novel means of imaging or HFGW surveillance might be developed in future to establish a system to allow for observing activities and materials in three dimensions, within and below structures and within the Earth and its oceans. Gravitational waves,

including HFGWs, pass through most material with little or no attenuation; but although they are not absorbed, their polarization (Li and Nan, 2009), phase velocity (causing refraction or bending of gravitational rays), backscatter, and/or other characteristics can be modified by a material object's texture and internal structure. For example, the change in polarization of a GW passing through a material object is discussed in Misner, Thorne, and Wheeler (1973): "In the real universe there are spacetime curvatures due not only to the energy of gravitational waves, but also more importantly to the material [objects and structures] content of the universe ... its wavelength changes [based on gravitational red shift] and [the gravitational wave] backscatters off the curvature to some extent. If the wave is a pulse, then the backscatter will cause its shape and polarization..." It is difficult to theoretically establish the actual magnitude of the changes, especially at very high frequencies (10^9 Hz and higher) and to quantify them prior to HFGW generation/detection laboratory experiments.

4.5 2050 and Beyond

The phases of human space exploration may be divided into the following phases:

- Epoch 1 – Interplanetary Exploration
- Epoch 2 – Interstellar Exploration
- Epoch 3 – Intergalactic Exploration
- Epoch 4 – Universal Exploration

Each phase will have its own challenges and opportunities, but one can certainly speculate that the human need for connectedness and communication knows no bounds. So any scope of expansion beyond Epoch 1 will have enormous challenges in the area of communication. The vast distances involved will require some form of communication that entails faster than light (FTL) propagation; possibly by pre-positioning entangled pairs. While this is a highly speculative area, such schemes have been proposed for FTL HFGW. Both Fontana and Meholic (Fontana and Murad, 2007) and, especially, Beckwith 2010a, 2010b, 2010c, to be published) have proposed models of the universe, such as the trispace model, in which subluminal or luminal gravitational waves may couple into a super-luminal "parallel universe" inside which faster than light speeds are possible. Such as scheme would be required to communicate between star systems and galaxies if humankind is to maintain any type of cohesive civilization. Without communications we have a history of fractured civilization, and we slip into becoming our own worse enemy. Universal communication holds the lofty promise of universal peace. As a matter of fact, the Search for Extraterrestrial Intelligence (SETI) would be well served by monitoring HFGW transmissions – HFGW no doubt being the broadcast communications means of choice for an advanced civilization.

5.0 ACKNOWLEDGEMENTS

Transportation Sciences Corporation provided important services in the preparation of this Communications Study, especially support of travel required to access international HFGW research. The research published in technical papers authored by Gary V.

Stephenson, chief investigator for Seculine Consulting, (Stephenson, 2009a, Harper Stephenson, 2007 and Stephenson, 2009b) were crucial in the preparation of this Study and is gratefully acknowledged. Material for this Special Report was gleaned from visits to China, Singapore, Dubai, Oman, Al Maha, Hurgada, Cairo, Barcelona, Paris and Chicago. Special thanks are due to Ammar Sakaji, Editor of the *Electronic Journal of Theoretical Physics* Dubai, Christian Corda, Editor of the *The Open Astronomy Journal*, Shaaban Khalil of the British University of Cairo, Gloria Garcia-Cuadrado Head of Human Spaceflight and Advanced Concepts & Head of Communication Aerospace Research and Technology Centre, Barcelona, Spain and Bonnie Sue Baker, Scientific Associate, Transportation Sciences Corporation.

6.0 REFERENCES

- Baker, R. M L, Jr. (1967), *ASTRODYNAMICS: Applications and Advanced Topics*, Academic Press, New York and London
- Baker, R. M L, Jr. (2003), "Application of High-Frequency Gravitational Waves to imaging," paper HFGW-03-120, *Gravitational-Wave Conference*, The MITRE Corporation, May 6-9, pp. 2-4.
- Baker, R. M L, Jr. (2005), "Applications of High-Frequency Gravitational Waves (HFGWs)," in the Proceedings of *Space Technology and Applications International Forum (STAIF-2005)*, edited by M.S. El-Genk, American Institute of Physics Conference Proceedings, Melville, NY **746**, pp. 1308-1309.
- Baker, R. M L, Jr. (2006), "Novel formulation of the quadrupole equation for potential stellar gravitational-wave power estimation," *Astronomische Nachrichten* **327**, No. 7, pp. 710-713.
- Baker, R. M L, Jr., Woods, R. C. and Fangyu Li (2006), "Piezoelectric-Crystal-Resonator High-Frequency Gravitational Wave Generation and Synchro-Resonance Detection," after peer review published in the proceedings of *Space Technology and Applications International Forum (STAIF-2006)*, edited by M.S. El-Genk, American Institute of Physics Conference Proceedings, Melville NY **813**, pp. 1280-1289. <http://www.drrobertbaker.com/docs/AIP:%20HFGW%20Piezoelectric%20Generator.pdf>
- Baker, R. M L, Jr., Li, F. Y. and Li, R. (2006), "Ultra-High-Intensity Lasers for Gravitational Wave Generation and Detection" in the proceedings of *Space Technology and Applications International Forum (STAIF-2006)*, edited by M.S. El-Genk, American Institute of Physics Conference Proceedings, Melville NY **813**, pp.1249-1258. Available at: <http://www.drrobertbaker.com/docs/AIP:%20HFGW%20Laser%20Generator.pdf>
- Baker, R. M L, Jr., Stephenson, G. V. and Li, F. (2008), "Proposed Ultra-High Sensitivity HFGW Detector," after peer review published in the proceedings of *Space Technology and Applications International Forum (STAIF-2008)*, edited by M.S. El-Genk, American Institute of Physics Conference Proceedings, Melville, NY **969**, pp. 1045-1054. <http://www.gravwave.com/docs/Proposed%20UltraHigh%20Sensitivity%20HFGW%20Detector%2005-15-08.pdf>
- Baker, R. M L, Jr. (2009), "Input Power Requirements for High-Frequency Gravitational Wave Generators," After Peer Review, Accepted for Publication in the *Proceedings of the Space, Propulsion and Energy Sciences International Forum (SPESIF)*, 24-27 February, Edited by Glen Robertson. 3rd High-Frequency Gravitational Wave Workshop (Paper 036), American Institute of Physics Conference Proceedings, Melville, NY **1103**, pp. 591-598. Please see <http://www.drrobertbaker.com/docs/HFGW's%20Power%20Requirements.pdf>
- Beckwith, A. W. (2010a), "HFGW and the search for relic gravitons / entropy increase from the early universe," *Proceedings of the Space, Propulsion and Energy Sciences International Forum (SPESIF 2010)*, February 23-26, John Hopkins University Applied Physics Laboratory, Laurel, MD, U.S.A., Edited by Glen Robertson., American Institute of Physics Conference Proceedings, Melville, NY, USA.
- Beckwith, A. W. (2010b), "Detection of Gravitational waves with semi classical features and cosmological implications (of such semi classical features)," *Proceedings of the Space, Propulsion and Energy Sciences International Forum (SPESIF 2010)*, February 23-26, John Hopkins University Applied Physics Laboratory, Laurel, MD, U.S.A., Edited by Glen Robertson. (Paper 009), American Institute of Physics Conference Proceedings, Melville, NY, USA.
- Beckwith, A. W. (2010c), "Stretched neutrinos, and the supposed linkage to Gravitons/ HFGW data sets," *Proceedings of the Space, Propulsion and Energy Sciences International Forum (SPESIF 2010)*, February 23-26, John Hopkins University Applied Physics Laboratory, Laurel, MD, U.S.A.,

Edited by Glen Robertson. (Paper 009), American Institute of Physics Conference Proceedings, Melville, NY, USA.

- Bernard, P. Gemme, G., Parodi, R. and Picasso, E. (2001), "A detector of small harmonic displacement based on two coupled microwave cavities," *Review of Scientific Instruments* **72**, Number 5, May, pp. 2428-2437.
- Black, C. S. and Baker, R. M L, Jr. (2009), "Radiation Pattern for a Multiple-Element HFGW Generator," after peer review, accepted for publication in the *Proceedings of the Space, Propulsion and Energy Sciences International Forum (SPESIF)*, 24-27 February, Edited by Glen Robertson. 3rd High-Frequency Gravitational Wave Workshop (Paper 035). American Institute of Physics Conference Proceedings, Melville, NY **1103**, pp. 582-590.
<http://www.drrobertbaker.com/docs/Analyses%20of%20HFGW%20Generators%20and%20Radiation%20Pattern.pdf>
- Boccalet D., Desabbar V., Fortini P. and Gualdi C. (1970), "Conversion of Photons Into Gravitons and Vice Versa in a Static Electromagnetic Field," *Il Nuovo Cimento* **B70**, 129
- Braginsky, V. B. Grishchuk, L. P., Doroshkevich, A.G., Zeldovich, Ya. B. Noviko, I. D. and Sazhin, M. V. (1974), "Electromagnetic Detectors of Gravitational Waves," *Sov. Phys. JETP* **38**, p. 865.
- Braginsky, V. B. and Rudenko, Valentin N. (1978), "Gravitational waves and the detection of gravitational radiation," Section 7: "Generation of gravitational waves in the laboratory," *Physics Report (Review section of Physics Letters)* **46**, Number 5, pp. 165-200.
- Chapline, G. Nuckolls, F. J. and Woods, L. L. (1974), "Gravitational-radiation production using nuclear explosions," *Physical Review D*, **10**, Number 4, August, pp. 1064-1065.
- Chiao, R. Y. (2007), "New Direction for gravity-wave physics via 'Millikan oil drops'", 6 April, [arXiv:gr-qc/0610146v6](http://arxiv.org/abs/gr-qc/0610146v6)
- Chiao, R.Y., Wegter-McNelly, K. and Minter, S. J., (2009), "Do Mirrors for Gravitational Waves Exist?" [arXiv:0903.0661v1](http://arxiv.org/abs/0903.0661v1) [gr-qc], March 4.
- Chincarini, A and Gemme, G. (2003), "Micro-wave based High-Frequency Gravitational Wave detector," paper HFGW-03-103, *Gravitational-Wave Conference*, The MITRE Corporation, May 6-9.
- Cruise, A. M. (2000), "An electromagnetic detector for very-high-frequency gravitational waves," *Class. Quantum Gravity* **17**, pp. 2525-2530.
- Cruise, A. M. and Ingle, R. M. J. (2005), "A correlation detector for very high frequency gravitational waves," *Class. Quantum Grav.* **22**, 5479-5481.
- Cruise, A. M. (2008), "Very High Frequency Gravitational Waves," [Gravitational Wave Advanced Detector Workshop \(GWADW\)](http://www.gwadv.org/), Elba Conference, 17 May, slide presentation 132.
<https://indico.pi.infn.it/contributionDisplay.py?contribId=132&sessionId=13&confId=225>
- Clerk, A.A. (2008), "Quantum Noise & Quantum Measurement," (APS Tutorial on Quantum Measurement), McGill University website, <http://www.physics.mcgill.ca/~clerk/PDFfiles/APSQMeasTutorialMar08.pdf>.
- Dehnen, H. and Fernando Romero-Borja (2003), "Generation of GHz – THz High-Frequency Gravitational Waves in the laboratory," paper HFGW-03-102, *Gravitational-Wave Conference*, The MITRE Corporation, May 6-9.
<http://www.gravwave.com/docs/Analysis%20of%20Lab%20HFGWs.pdf>
- DeLogi W.K. and Mickelson A.R. (1977), "Electro-Gravitational Conversion Cross-Sections in Static Electromagnetic Fields," *Phys. Rev.* **D16**, pp. 2915-2927
- Douglass, D.H. and Braginsky, B. (1979), "Gravitational-radiation experiments," in "General relativity: an Einstein centenary survey" Ed. Hawking S.W. and Israel W. (CUP, UK), 90-137.
- Eardley, et al. (2008) "High Frequency Gravitational Waves," JSR-08-506, October, the JASON defense science advisory panel and prepared for the Office of the Director of National Intelligence.
- Einstein, Albert (1915), [Einstein, Albert](http://www.mpiwg-berlin.mpg.de/cgi-bin/toc/toc.x.cgi?dir=6E3MAXK4&step=thumb) (1915), "[Die Feldgleichungen der Gravitation](http://www.mpiwg-berlin.mpg.de/cgi-bin/toc/toc.x.cgi?dir=6E3MAXK4&step=thumb)", *Sitzungsberichte der Preussischen Akademie der Wissenschaften zu Berlin*: 844–847, <http://nausikaa2.mpiwg-berlin.mpg.de/cgi-bin/toc/toc.x.cgi?dir=6E3MAXK4&step=thumb>, retrieved on 12 September 2006 (General Relativity)
- Einstein, Albert (1916), [Einstein, Albert](http://www.alberteinstein.info/gallery/gtext3.html) (1916), "[Die Grundlage der allgemeinen Relativitätstheorie](http://www.alberteinstein.info/gallery/gtext3.html)" (PDF), *Annalen der Physik* **49**, <http://www.alberteinstein.info/gallery/gtext3.html>, retrieved on 3 September 2006 (Gravitational Waves)
- Einstein, Albert, (1918) Über Gravitationswellen. In: *Sitzungsberichte der Königlich Preussischen Akademie der Wissenschaften*, Berlin (1918), 154–167. (Quadrupole equation and formalism)
- Fontana, G. (1998), "A possibility of emission of high frequency gravitational radiation from junctions between d-wave and s-wave superconductors," *Preprint, Faculty of Science, University of Trento*, 38050 Povo (TN), Italy, pp. 1-8. <http://xxx.lanl.gov/html/cond-mat/9812070>.
- Fontana, G. and Baker, R. M L Jr. (2003), "The high-temperature superconductor (HTSC) gravitational laser (GASER)," paper HFGW-03-107, *Gravitational-Wave Conference*, The MITRE Corporation, May 6-9.
- Fontana, G. and Baker, R. M L, Jr. (2006), "Generation of Gravitational Waves with Nuclear Reactions," after peer review published in the proceedings of *Space Technology and Applications International Forum (STAIF-*

- 2006), edited by M.S. El-Genk, American Institute of Physics Conference Proceedings, Melville NY **813**, pp. 1352-1358. <http://www.drrobertbaker.com/docs/AIP:%20HFGW%20Nuclear%20Generator.pdf>
- Fontana, G. and Baker, R. M L Jr. (2007), "HFGW-Induced Nuclear Fusion." after peer review accepted for the *Space Technology and Applications International Forum (STAIF-2007)*, edited by M.S. El-Genk, American Institute of Physics Conference Proceedings, Melville, NY **880**, Feb. 26, pp. 1156-1164. <http://www.gravwave.com/docs/AIP:%20HFGW%20Nuclear%20Fusion.pdf>
- Fontana, G. and Murad, P. (2007), "Hyperspace for Space Travel," *SpaceTechnology and Applications International Forum (STAIF-2007)*, edited by M. S. El-Genk, American Institute of Physics, Melville, New York **880**, pp. 1117-1125.
- Fontana, G. and Binder, B. (2009), "Electromagnetic to Gravitational wave Conversion via Nuclear Holonomy," after peer review accepted for publication in the *Proceedings of the Space, Propulsion and Energy Sciences International Forum (SPESIF)*, 24-27 February, Edited by Glen Robertson. (Paper 015), American Institute of Physics Conference Proceedings, Melville, NY **1103**, pp. 524-531.
- Forward, R. L. and Baker, R. M L, Jr. (1961), "Gravitational Gradients, Gravitational Waves and the 'Weber Bar'," Lecture given at the *Lockheed Astroynamics Research Center*, 650 N. Sepulveda, Bel Air, California, USA, November 16th. *Lockheed Research Report RL 15210*. (Forward coined the term "High-Frequency Gravitational Waves.")
- Gertsenshtein, M. E. (1962), "Wave resonance of light and gravitational waves," *Soviet Physics JETP*, Volume 14, Number 1, pp. 84-85.
- Grishchuk, L. P. and Sazhin M. V. (1974), "Emission of gravitational waves by an electromagnetic cavity." *Soviet Physics JETP* **38**, Number 2, pp. 215-221.
- Grishchuk, L. P. (1977), "Gravitational Waves in the Cosmos and the Laboratory," *Usp. Fiz. Nauk* **121**, pp 629-656.
- Grishchuk, L. P. (2003), "Electromagnetic generators and detectors of gravitational waves," paper HFGW-03-119, *Gravitational-Wave Conference*, The MITRE Corporation, May 6-9.
- Grishchuk, L.P. (2007) "High-Frequency Relic Gravitational Waves, their Detection and New Approaches," in the proceedings of the HFGW2 Workshop, Institute Austin (IASA), Texas, September 19-21; <http://earthtech.org/hfgw2/>, accessed 11/06/08.
- Grishchuk, L.P. (2008), "Discovering Relic Gravitational Waves in Cosmic Microwave Background Radiation," *Proceedings of the School*, Eds. I. Ciufolini and R. Matzner, (in press) Springer 2008, [arXiv:0707.3319v3](https://arxiv.org/abs/0707.3319v3)
- Halpren, L. and Laurent, B. (1964), "On the gravitational radiation of a microscopic system," *IL NUOVO CIMENTO*, Volume XXXIII, Number 3, pp. 728- 751.
- Harper, C. and Stephenson, G.V. (2007), "The Value Estimation of an HFGW Frequency Time Standard for Telecommunications Network Optimization," after peer review published in the proceedings of *Space Technology and Applications International Forum (STAIF-2007)*, edited by M.S. El-Genk, American Institute of Physics Conference Proceedings, Melville, NY **880**, pp. 1083-1091. <http://www.gravwave.com/docs/AIP:%20HFGW%20Telecommunications.pdf> and http://www.gravwave.com/ppt/HFGW%20Telecom_files/frame.htm
- Hou B., Xu G., Wong H.K., and Wen W.J. (2005), "Tuning of photonic band gaps by a field-induced structural change of fractal metamaterials," *Optics Express* **13**, pp. 9149-9154.
- Ingle, R. M. J. (2005), "Implementation and Cross Correlation of Two High Frequency Gravitational Wave Detectors," PhD Thesis, *The University of Birmingham*, January.
- Kippenberg, T. J. and Vahala, K. J. (2008), "Cavity Optomechanics: Back-Action at the Mesoscale," *Science* **321**, 1172-1176, August 29
- Klemperer, W. B. and Baker, R. M L, Jr. (1957) "Satellite librations," *Astronautica ACTA*, Fasc. 1, 16-27.
- Kolosnitsyn, N. I. and Rudenko, V. (2007), "Generation and Detection of the High Frequency Gravitational Radiation in a Strong Magnetic Field," in the proceedings of the *HFGW2 Workshop*, Institute of Advanced Studies at Austin (IASA), Texas, September 19-21; <http://earthtech.org/hfgw2/>
- Kraus, J. D. (1991), "Will gravity-wave communication be possible?" *IEEE Antennas & Propagation Magazine*, Volume 33, Number 4, August.
- Landau, L. D. and Lifshitz, E. M. (1975), *The Classical Theory of Fields*, Fourth Revised English Edition, Pergamon Press, pp. 348, 349, 355-357.
- Landy, N. I., Sajuyigbe, S., Mock, J. J., Smith, D. R. and Padilla (2008), "Perfect Metamaterial Absorber," *Physical Review Letters* **100**, pp. 207402-1-4, May 23.
- Lawrence, C. R. (2004), "QUIET, The Q/U Imaging Experiment, Measuring CMB Polarization with Massive Arrays of Coherent Detectors," C. R. Lawrence, *JPL & the QUIET Collaboration*, Zel'dovich-90, *Space Research Institute*, December 21.
- Li, F. Y., Tang M. and Zhao P. (1992), "Interaction Between Narrow Wave Beam-Type High Frequency Gravitational Radiation and Electromagnetic Fields," *Acta Physica Sinica* **41** 1919-1928
- Li, F. Y. and Tang M.X. (1997), "Positive definite problem of energy density and radiative energy flux for pulse cylindrical gravitational wave," *Acta Physica Sinica* **6** 321-333.
- Li, F. Y., Meng-Xi Tang, Jun Luo, and Yi-Chuan Li (2000) "Electrodynamical response of a highenergy

- photon flux to a gravitational wave,” *Physical Review D* **62**, July 21, pp. 044018-1 to 044018 -9.
- Li, F. Y., Meng-Xi Tang, and Dong-Ping Shi, (2003), “Electromagnetic response of a Gaussian beam to high-frequency relic gravitational waves in quintessential inflationary models,” *Physical Review B* **67**, pp. 104006-1 to -17.
- Li, F. Y. and Nan Yang (2004), “Resonant Interaction between a Weak Gravitational Wave and a Microwave Beam in the Double Polarized States Through a Static Magnetic Field”
Journal-ref: Chin. Phys. Lett. **21**, No. 11, p. 2113.
- Li, F. Y. and Li, Ruxin (2006), “Ultra-High-Intensity Lasers for Gravitational Wave Generation and Detection,” after peer review published in the proceedings of *Space Technology and Applications International Forum (STAIF-2006)*, edited by M.S. El-Genk, American Institute of Physics Conference Proceedings, Melville NY **813**, pp.1249-1258. Available at:
<http://www.drrobertbaker.com/docs/AIP:%20HFGW%20Laser%20Generator.pdf>
- Li, F. Y. and Baker, R. M L, Jr. (2007), “Detection of High-Frequency Gravitational Waves by Superconductors,” *6th International Conference on New Theories, Discoveries and Applications of Superconductors and Related Materials*, Sydney, Australia, January 10; *International Journal of Modern Physics* **21**, Nos. 18-19, pp. 3274-3278.
- Li F.Y., Baker R. M L and Fang Z. (2007), “Coupling of an open cavity to a microwave beam: a possible new scheme for detecting high-frequency gravitational waves,” after peer review accepted for the Proceedings of the AIP Space Technology and Applications Int. Forum, Albuquerque, New Mexico **880**, 1139-1147.
- Li F. Y., Baker R. M L, Jr., Fang Z., Stephenson G.V. and Chen, Z. (2008), “Perturbative Photon Fluxes Generated by High-Frequency Gravitational Waves and Their Physical Effects,” *European Phys. J. C* **22**, Nos. 18-19, 30 July; available at <http://www.gravwave.com/docs/Li-Baker%206-22-08.pdf> (please see Appendix B).
- Li and Fangyu Yang Nan (2009), “Phase and Polarization State of High-Frequency Relic Gravitational Waves,” *Journal of Chinese Physics Letters* (in press)
- Li. F. Y., Yang, N., Fang, Z., Baker, R. M L, Jr., Stephenson, G. V. and Wen, H. (2009), “Signal Photon Flux and Background Noise in a Coupling Electromagnetic Detecting System for High Frequency Gravitational Waves,” *Phys. Rev. D* accepted for publication August 18, 2009.
- Minter, S. J., Wegter-McNelly, K. and Chiao, R. Y. (2009), “Do Mirrors for Gravitational Waves Exist?”
arXiv:0903.0661v5, March 24.
- Misner, C. W. Thorne, K. and Wheeler, J. A. (1973), *Gravitation*, W. H. Freeman and Company, New York.
- Nishizawa, Atsushi, Seiji Kawamura, Tomotada Akutsu, Koji Arai, Kazuhiro Yamamoto, Daisuke Tatsumi, Erina Nishida, Masa-aki Sakagami, Takeshi Chiba, Ryuichi Takahashi, and Naoshi Sugiyama (2008), “Laser-interferometric detectors for gravitational wave backgrounds at 100 MHz : Detector design and sensitivity,” to be published *Physical Review D* **15**. American Physical Society.
- Ottaway, D. J. et al (1998), “A Compact Injection-Locked Nd:YAG Laser for Gravitational Wave Detection,” *IEE Journal of Quantum Electronic* **34**, Number 10, October 9.
- Pegoraro, F. ., Radicati, L. A., Bernard, Ph. and Picasso, E. (1978), *Phys. Rev. Letters A* **68**, p. 165.
- Pinto, I. P. and Rotoli, G. (1988), “Laboratory generation of gravitational waves?” *Proceedings of the 8th Italian Conference on General Relativity and Gravitational Physics*, Cavlese (Trento), August 30 to September 3, World Scientific-Singapore, pp. 560-573.
- Romero, F. B and Dehnen, H. (1981), “Generation of gravitational radiation in the laboratory,” *Z. Naturforsch* **36a**, pp. 948-955.
- Rudenko, V. N. and Sazhin, M. V. (1980), “Laser interferometer as a gravitational wave detector,” *Sov. J. Quantum Electron* **10**, November, pp. 1366-1373.
- Rudenko, V. N. (2003), “Optimization of parameters of a coupled generator-receiver for a gravitational Hertz experiment,” paper HFGW-03-113, *Gravitational-Wave Conference*, The MITRE Corporation, May 6-9.
- Shannon, C. B. (1948), *Bell Systems Technical Journal*, Volume **27**, Number 379, p. 623.
- Shawhan, P. S. (2004), “Gravitational Waves and the Effort to Detect them,” *American Scientist* **92**, 356. (Explains why LIGO cannot detect HFGWs.)
- Stephenson, G. V. (2009a), “Lessons for Energy Resonance HFGW Detector Designs Learned from Mass Resonance and Interferometric LFGW Detection Schemes,” after Peer Review, accepted for Publication in the *Proceedings of the Space, Propulsion and Energy Sciences International Forum (SPESIF)*, 24-27 February, Edited by Glen Robertson. (Paper 016), American Institute of Physics Conference Proceedings, Melville, NY **1103**, pp. 532-541.
- Stephenson, G. V. (2009b) “The Standard Quantum Limit for the Li-Baker HFGW Detector,” after Peer Review, accepted for Publication in the *Proceedings of the Space, Propulsion and Energy Sciences International Forum (SPESIF)*, 24-27 February, Edited by Glen Robertson. (Paper 023), American Institute of Physics Conference Proceedings, Melville, NY **1103**, pp. 542-547.
<http://www.gravwave.com/docs/HFGW%20Detector%20Sensitivity%20Limit.pdf>

- Tobar, M., **1729-1736** E. (1995), "Characterizing multi-mode resonant-mass gravitational wave detectors," *Journal of Applied Physics* **28**, pp. 1729-1736
- Tobar, M. E. (1999), "Microwave Parametric Transducers for the Next Generation of Resonant-Mass Gravitational Wave Detectors," *Dept. of Physics, the University of Western Australia*, Nedlands, 6907 WA, Australia.
- Weber, J. (1964), "Gravitational Waves" in *Gravitation and Relativity*, Chapter 5, pp. 90-105, W. A. Benjamin, Inc., New York.
- Wen W.J., Zhou L., Li J.S., Ge W.K., Chan C.T. and Sheng P. (2002), "Sub-wavelength photonic band gaps from planar fractals," *Phys. Rev. Lett.* **89** 223901.
- Woods, R. C. and Baker, R. M L, Jr. (2005), "Gravitational Wave Generation and Detection Using Acoustic Resonators and Coupled Resonance Chambers," after peer review published in the proceedings of *Space Technology and Applications International Forum (STAIF-2005)*, edited by M.S. El-Genk, American Institute of Physics Conference Proceedings, Melville, NY **746**, 1298.
- Woods, R. C. (2006), "High-Frequency Gravitational Wave Optics," in the proceedings of *Space Technology and Applications International Forum (STAIF-2006)*, edited by M.S. El-Genk, American Institute of Physics Conference Proceedings, Melville NY **813**, 1305-1312.
- Woods, R. C. and Baker, R. M L, Jr., (2009) "Generalized Generators of Very-High-Frequency Gravitational Waves Including Ring and Helix Devices," after peer review accepted for publication in the *Proceedings of the Space, Propulsion and Energy Sciences International Forum (SPESIF)*, 24-27 February, Edited by Glen Robertson, American Institute of Physics Conference Proceedings, Melville, NY **1103**, pp. 515-523.
- Yariv A. (1975), "Quantum electronics," 2nd Ed. (Wiley, New York), 1975
- Yoon, K. W., Ade, P. A. R., Barkats, D., et al. (2006), "The Robinson Gravitational Wave Background Telescope (BICEP): a bolometric large angular scale CMB polarimeter," in Proceedings of the SPIE, **6275**: Millimeter and Submillimeter Detectors and Instrumentation for Astronomy III, ed. J. Zmuidzinas, W. S. Holland, S. Withington, and W. D. Duncan, Bellingham, Washington, astro-ph/0606278
- Zhou L., Wen W., Chan C.T. and Sheng P. (2003), "Reflectivity of planar metallic fractal patterns," *Appl. Phys. Lett.* **82** 1012-1014.

APPENDIX A

Statement of Work to be Performed (Preliminary, November 1, 2009)

1. Summary of experimental arrangement and operation of the detector

The Li-Baker high-frequency gravitational wave (HFGW) detector introduces the conversion of gravitational waves to electromagnetic (EM) microwaves in the presence of a microwave Gaussian beam (GB), having the same frequency and similar direction and phase as the HFGWs to be detected (termed a “synchro-resonant EM beam”), and also in the presence of a magnetic field. As validated by seven journal articles, independently peer reviewed by scientists presumably well versed in general relativity, this conversion leads to microwave detection photons moving in a direction perpendicular to the plane of the synchro-resonant beam and the magnetic field, and will enable ultra-high sensitivity HFGW detection. The basic geometry is shown in Fig. 1. The arrangement has four novel and important advantages over previous GW detectors:

- (1) under the synchro-resonant condition, a transverse first-order perturbative (detection) photon flux (PPF) proportional to the amplitude of the HFGWs A (not A^2 as in the case of the inverse Gertsenshtein effect) can be produced where the transverse background photon flux (BPF) vanishes, improving the signal-to-noise ratio;
- (2) the resonant effect is sensitive to the propagation direction of the GW;
- (3) the detected signal PPF, concentrated or focused by the reflectors to the high-sensitivity microwave photon flux receivers, and the PPF has a small decay rate (Wen *et al.*, 2002; Zhou *et al.*, 2003; Hou *et al.*, 2005) compared with the large decay and effective absorption of the background photon flux (BPF) by the detector’s walls that also exhibits negligible scattering and
- (4) the fact that with the magnetic field “off” only the BPF and other noise is present and with the magnetic field “on” the detection photons or PPF are added so that a subtraction of these measurements will, except for stochastic effects, identify the PPF detection-photon signal.

These properties ensure that the effects produced by the GWs can be distinguished from the noise background under suitable conditions. Noise sources resulting from diffraction from the GB’s imperfections and the reflector’s edges, blackbody emissions from the enclosure walls, (including vibrations and inherent temperature variations), Johnson noise in the HEMIT amplifiers, shot noise in the diffraction fields, noise in the generation of the GB (microwave transmitter) and the magnetic field, etc. are found to be negligible or suppressible by adjustments to the detector’s components during the detector’s acceptance testing.

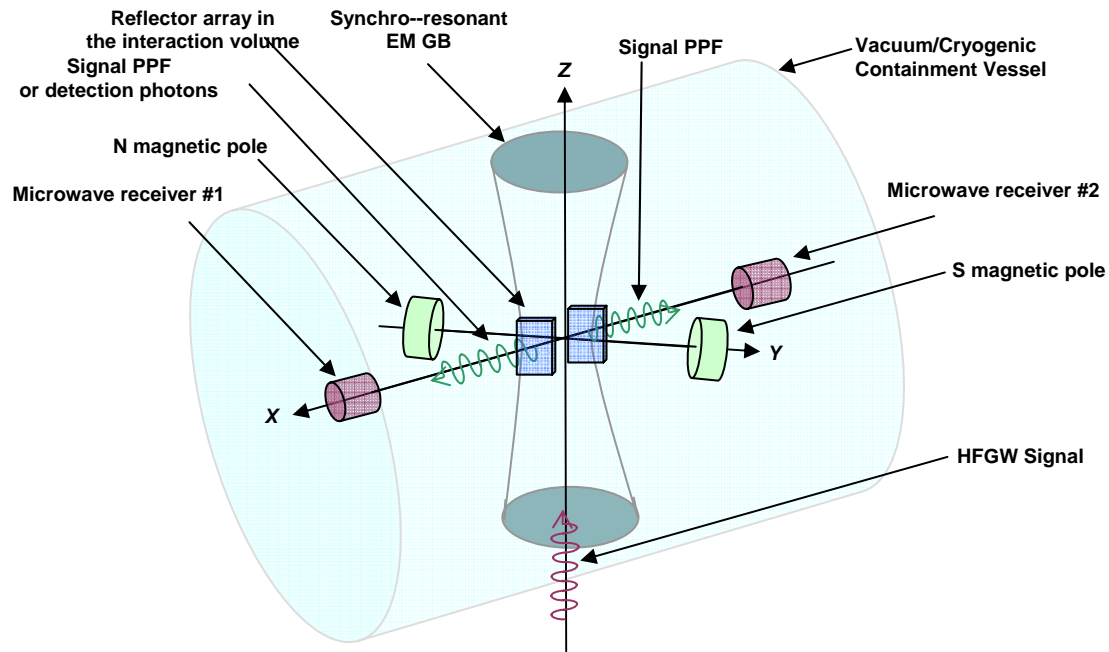

Fig. 1. Schematic of the basic geometry of the Li-Baker HFGW Detector

When the EM-detection photons (the perturbative photon flux or PPF created in an interaction or reaction volume) are focused on the microwave receivers #1 and #2 (by the reflectors in the y - z plane of Fig. 1) and the background photon flux (BPF) or noise is suppressed by an absorbing mat tuned to 10 GHz, which corresponds to the sharp maximum peak of Gravitational Wave Energy Density or Ω_{gw} in Fig. 2, then the sensitivity to 10 GHz relic HFGWs is greatly improved (Baker, Stephenson and Li, 2008). The interaction or reaction zone or volume is about 30cm long (or possibly longer), 6cm to 9cm wide and roughly cylindrically shaped like the Gaussian beam (GB) as sketched in Fig. 1. This is the interaction volume or zone where the magnetic field (y -directed) intersects or overlaps the GB (z -directed) along with the z -directed HFGWs. It is the synchro-resonance interaction volume where detection photons are created. The EM detection photons (PPF) are created and propagate in both the $+x$ and $-x$ -directions, according to the analysis given by Li *et al.* (2008 and 2009), and are reflected or focused to the microwave receivers by the non-magnetic semi-paraboloid reflectors (Baker, Stephenson and Li, 2008) fabricated from aluminum, copper, non-ferromagnetic stainless steel, etc.

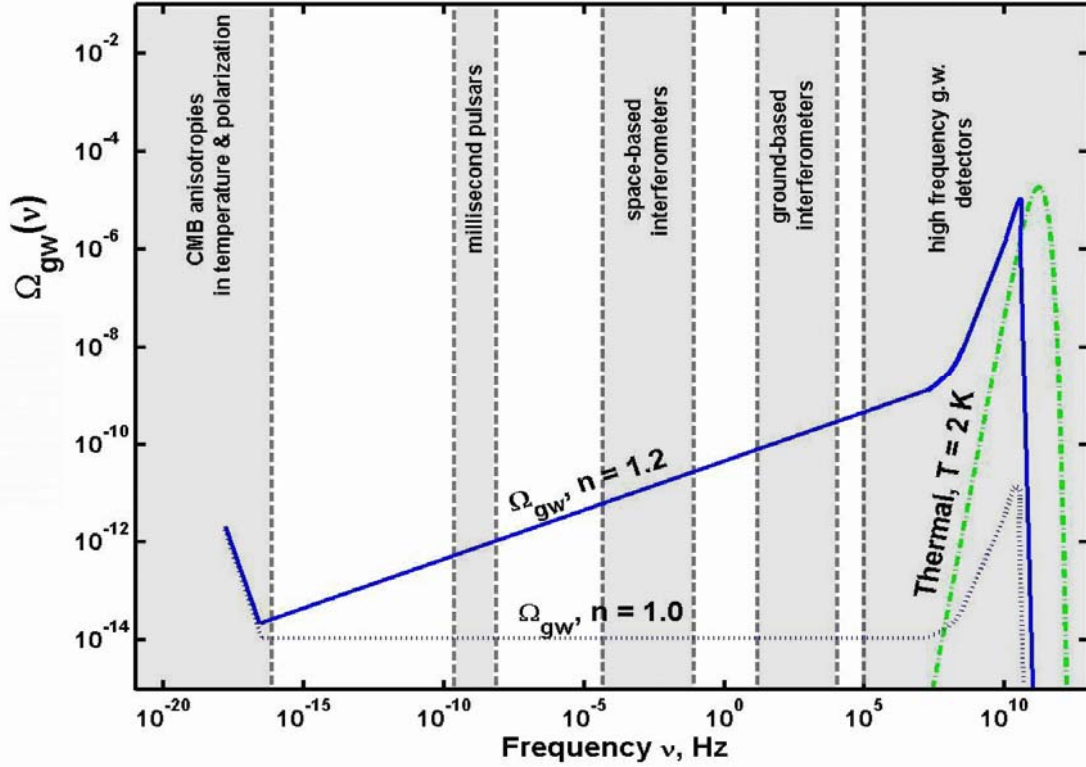

Fig. 2: Predicted Relic Gravitational Wave Energy Density as a Function of Frequency (Grishchuk, 2007)

Noise sources external to the HFGW detector will be eliminated by the detector’s metal-conductor cryogenic containment vessel in order to provide an effective Faraday cage. As discussed by Lee and Wan (2006), suitable geometric structures (e.g., rounded corners) or baffles are required to eliminate the background photon flux (BPF). Internal thermal noise (that is, thermal photons, which might reach the microwave receivers) will be eliminated by maintaining the containment vessel at a cryogenic temperature. A non-microwave-reflecting interior enclosure, shaped to conform to the high-intensity continuous microwave Gaussian beam (GB), will reduce any BPF radiated normal to the GB (z-axis) or side lobes. Such BPF will be further attenuated by a series of non-microwave-reflecting-mat baffles or detector walls forming a “tunnel” to the sensitive microwave receivers on each side of the GB and perpendicular to the static magnetic field (Baker, Stephenson and Li, 2008). All these noise sources can be distinguished by turning the magnetic field “on” and “off”. The detection bandwidth affects the SNR in the usual manner. In a subsequent design development a superconductor enclosure could also be configured as a resonant cavity producing a standing electromagnetic (EM) wave (both in the interaction volume and leading to the detectors) to reach the required power density with greatly reduced power input and increase sensitivity (Li and Baker, 2007) beyond its current sensitivities to HFGW amplitudes of $A = 10^{-32}$. In order to shed the microwave power of the GB, sinks or dissipaters or recyclers (rectifiers) could be used. Compartments contiguous to the detector containment vessel, but sealed from it by microwave transparent windows, will house the GB microwave transmitter and the microwave absorber in order to eliminate heat transfer to the actual detector enclosure. A high vacuum at about 10^{-7} Torr will be necessary for cryogenic operation and ensures that there will be negligible mass in the HFGW path in the interaction volume and negligible Rayleigh scattering from the GB to the microwave receivers.

For the prototype proof-of-concept test, an experimental run of about 2 to 3 days would be carried out. It consists of 200 one-thousand-second data-collection or accumulation intervals. Every other interval is without the magnetic field on. The average of the signals for the 100 intervals without the magnetic field is subtracted from the 100 signal sets with the magnetic field turned on, which is defined as ΔS . If ΔS is a positive quantity, then the standard deviation of the signals averaged over the one-hundred intervals without a magnetic field will be computed, which is defined as σS . The computation of the average and the σS will establish whether the results are outside the statistical range to be expected and if a detection event has occurred. If a detection event has not occurred, then another frequency and/or bandwidth will be selected and another experimental run completed and so on.

2. Plan of work

The proposed work will include the project planning and design activity at the Contractor, Transportation Sciences Corporation or **TSC** (which has had prior contracts with the US Government), and graphics and engineering plans preparation activity subcontracted to **GravWave® LLC** (which owns the Li-Baker HFGW Detector Patents) and also a subcontract to **LSU** (where Project Scientist R. Clive Woods is Chairman and Voorhies Distinguished Professor, Department of Electrical and Computer Engineering), which will also provide additional systems engineering services. The proposers are also associated with a large network of Chinese scientists and engineers working on HFGW and led by Prof. Fangyu Li at *Chongqing University*, including the *University of Science and Technology of China* (Hefei), the *Chengdu Microwave Laboratory of the China Academy of Engineering Physics*, and the *Hong Kong University of Science and Technology*, which will enable comprehensive international research discussions to take place regarding the design and development effort. This statement of work requests support for the US design effort only. (The Chinese effort on HFGW research is separately funded by the **National Basic Research Program of China** under grant number 2003CB716300, the **National Natural Science Foundation of China** under grant number 10575140, the **Foundation of China Academy of Engineering Physics** under grant numbers 2008TO401 and 2008TO402, and the **Nature Science Foundation of Chongqing** under grant 8562.) **In June 2008, the Institute of Electronic Engineering of the China Academy of Engineering Physics was awarded 3,020,000 Yuan (US\$430,000) for research on HFGWs.** Throughout the project; **TSC** will monitor the Chinese work and will exchange research information. The relationship between the US and Chinese Li-Baker detector efforts is expected to be similar to that between the US LIGO and the GEO600, Virgo and TAMA foreign research efforts.

The program defined by the present work statement is to develop designs, plans and specifications for the Li-Baker configuration for ultra-high sensitivity detection of relic high-frequency gravitational waves (HFRGWs) in the laboratory as a proof-of-concept test prior to the Li-Baker Detector being utilized in a laboratory HFGW generation and detection experiment. The first goal will be to develop the design to a stage where the likely performance can be evaluated in detail. Following a future proposal, the Li-Baker detector will subsequently be built and used for the basic-science purposes of sensing HFRGWs having their origin related to the “big bang”, as well as for detecting laboratory-generated HFGWs (Romero and Dehnen, 1981; Baker, 1999, 2000; Woods and Baker, 2005, 2009). Use will primarily be made of “off-the-shelf” components, and components described in the open scientific literature and in the various patents issued to the PI **Robert M L Baker, Jr.** (Baker, 1999, 2000, 2001 and Patents Pending). Other components will be designed by the project participants during the Detector Design (**DD**) process. The project plan and timing are described below under separate headings for each component of the work.

At the actual delivery of a Li-Baker HFGW Detector, following the completion of the design-specification, will involve an “Acceptance Test” as follows

Li-Baker HFGW Detector Acceptance Testing

1.1. Magnet Off and GB Off

The receivers will receive noise resulting from lack of a tight Faraday Cage and/or thermal effects. A 10 GHz source would be moved to search for Faraday Cage “leaks.” If they existed, such leaks once located would be corrected. The temperature of the detector enclosure would be measured to be what is calculated to be sufficient to remove all thermal or blackbody noise, 480 mK. If not negligible, then the enclosure will be cooled to a lower temperature until the noise is eliminated. Noise inherent in the microwave receivers themselves will be analyzed and minimized.

1.2. Only the Magnet On

The magnet is not expected to produce noise at 10 GHz, but if noise is detected, then the superconducting magnet design will be improved using absorbing pyramid and/or metamaterial baffles or changing components location until the magnet noise is found and eliminated.

1.3. Magnet Off and GB On

This is the more challenging situation and it will be divided into GB spillover noise and GB system noise. The initial acceptance test will be to slightly vary the frequency of the GB and look for a minimum of noise (with the magnet off ONLY noise will be present at the receivers).

3. Specific Tasks

DD1.1 Containment Vessel

Design of the cryogenic containment vessel and vacuum system: **R.C. Woods (LSU) + graduate student, G.V. Stephenson (TSC), C. S. Black (GravWave® LLC)**. This will be divided into four subtasks. Each subtask will include a detailed (ready for procurement and construction) plans and specifications activity by draftsmen and technical editor(s) (**GravWave® LLC**)

DD1.1.1 Selection of material for the containment vessel: this choice will be made in light of the vessel’s approximate size and shape, overall approximately 2m diameter and 3m length. Manufacturing ultra-high vacuum chambers requires fabrication that ensures leak-free performance. For example, Meyer Tool & Manufacturing, Inc. (Oak Lawn, Illinois) supplies custom chambers for ultra-high vacuum (UHV) applications. Companies such as Meyer will be consulted and/or visited to evaluate their manufacturing capability. The final selection from the expected short-list of titanium, stainless steel and/or aluminum containment vessels will be made based upon manufacturer recommendation and evaluation of test data.

DD1.1.2 Detailed design of brackets and fixtures for the internal equipment, wiring, piping and through-wall connections: the general principles demonstrated by existing Magnetic Resonance Imaging (MRI) system designs (e.g. from Siemens MRI,

GE Healthcare, and others) will be followed to determine the most compatible design of the internal equipment, wiring, piping and through-wall connections for the HFGW detector. A cryostat or cryogenic containment vessel supported inside the vacuum vessel will house the superconducting magnet assembly necessary for the Li-Baker detector. Through-wall fittings and seals for copper leads supplying the magnet and other internal apparatus will be needed. Design of brackets, wiring, and piping of detector equipment will also be based upon input from the other tasks.

DD1.1.3 Design of vacuum system: there are a large number of “off-the shelf” Ultra-High Vacuum (UHV) equipment providers such as: Varian, Inc. (Lexington, Massachusetts), Kimball Physics, Inc. (Wilton, New Hampshire), and Edwards High Vacuum Ltd. (UK), amongst others. Those with capability for producing a system able to evacuate the chamber to about 10^{-7} Torr for the HFRGW detector will be approached to undertake a detailed specification.

DD1.1.4 Detailed design of size and shape of containment vessel: determination of the containment vessel’s precise dimensions will be based upon the final designs of the equipment determined by the other tasks and will integrate all the specific sub-task designs, resolving any conflicts between units. Initially, the vessel is anticipated to be cylindrical, approximately 2m in diameter and 3m in length.

DD1.2 Signal Processing

Design of the recording apparatus hardware and software development that will be needed to handle merging the two receiver inputs over an averaging period of up to 1,000s: **R. M L Baker (TSC), G.V. Stephenson (TSC)**. This will require the conceptual design of digitizing hardware and software to handle the data gathered, including the combination of multiple receiver signals, the use of delay histograms, statistical filtering techniques, and the study of false alarm pitfalls in non-linear signal processing.

There is much overlap with this area and DD1.5, the design of the detection receivers. The expected GW signal structure must be characterized to optimize the matched filtering needed. The definition of a detection event is the foremost consideration, and will be studied both in terms of the threshold level and in terms of the statistics of exceeding that level. Expected signal to noise enhancements (“processing gain”) will be investigated for various filtering and processing options, and the effect of the Q-factor inherent in the detection apparatus will be included this area of investigation. Linear processing techniques such as multiple receiver combination and delay histogram searches and a Kalman filter will be studied, and non-linear signal processing will also be considered, including its effect on detectability, as well as its effect on false alarm generation. This task includes the selection of the best computing and digitizing recorder platforms for the signal-processing needed.

Also under this task is an investigation of whether magnetic field modulation can be used to advantage in this detector. Any scattered BPF does not depend upon the applied magnetic field or on the GW. Therefore, the wanted PPF can be “labeled” by varying the applied (nominally static) magnetic field in some way. A common technique in magnetic resonance experiments is to use field modulation coils that superimpose upon the constant applied magnetic field a time-varying component at low frequency (e.g., possibly a square wave around 50Hz but asynchronous with the commercial power supply frequency). Then the PPF is “labeled” as whatever is recovered from the receivers at the same frequency as (and indeed phase-locked to) the modulation, so therefore the PPF can be distinguished from scattered BPF very easily. Typically a lock-in amplifier (referenced to the field modulation) is used to recover the signal in such an arrangement, which provides significant noise rejection by effectively reducing the detection bandwidth.

A detailed layout plan for positioning the Signal-Processing hardware and the interconnections will be completed by the **GravWave® LLC** draftsmen.

DD1.3 Microwave Transmitter (Gaussian beam or GB)

Design of the microwave transmitter for the Gaussian beam (GB), directed towards the central reflector array: **R.C. Woods (LSU) + graduate student, R. M L Baker (TSC) and G.V. Stephenson (GravWave® LLC)**. This is expected to require 10 to possibly 10,000W (1,000W nominal) at around 10GHz, with an associated power supply and appropriate safety interlocks. Possible technologies include solid-state, magnetron, traveling-wave tube (TWT), or high-power klystron, and specifications will be developed under this component of the work. These are all mature technologies and commercial units will suffice. Possible suppliers include: Microwave Power Inc. (Santa Clara, California; solid-state, up to 500W); ETM Electromatic Inc. (Newark, California; TWT or klystron, up to 10kW); and Toshiba Electron Tube and Devices Co., Ltd. (Japan; TWT or klystron, over 10kW). Generally speaking, wideband solid-state amplifiers produce less output power than medium bandwidth models or narrow-band tube designs, so that the compromise here will be to decide whether to accept lower power in favor of wide tunability. Also required is a suitably matched transmit antenna. Again, commercial designs will suffice, such as those from Rozendal Associates Inc. (Santee, California), ETS-Lindgren (Cedar Park, Texas), or Orban Microwave Products (El Paso, Texas). The compromise that must be worked out in the antenna design is that a high-gain antenna is needed to constrain the GB to be within the resonance cavity or interaction volume (so that microwave input power is not wasted), but a high-gain antenna is less tunable than a broadband low-gain antenna. As in other work areas of this statement of work, the complete design will need to establish the cost-performance tradeoff issues surrounding the various approaches.

DD1.4 Reflectors and Microwave Absorbers

Design of the microwave reflectors/absorbers e.g., metamaterials and fractal membranes at select frequencies (Landy, *et al.* 2008, Wen *et al.*, 2002; Zhou *et al.*, 2003) and other off-the-shelf high-performance microwave absorbers: **R. M L Baker (TSC) and C. S. Black (GravWave® LLC)**. Each subtask will include a detailed (ready for procurement and construction) plans and specifications activity by draftsmen and technical editor(s) (**GravWave® LLC**).

DD1.4.1 Design of the semi-paraboloidal **reflectors** at the waist of the Gaussian beam including their paraboloidal form. An analysis will be completed to determine the optimal material of the two back-to-back reflectors (aluminum, copper, non-ferromagnetic stainless steel, are the obvious leading candidates). The paraboloidal reflectors will be designed that can be fabricated to focus the PPF at the planned locations of the microwave receivers.

DD1.4.2 The **interior** of the containment vessel (except for a sealed opening at the Gaussian-beam transmitter end) must be treated to eliminate exterior sources of noise. Either a Faraday Cage composed of microwave resistant materials or simply the metal of the containment vessel are possibilities. Both will be examined in detail to determine the optimal approach. A design compatible with the containment-vessel shape (DD1.1.4) and placement of interior detector elements and baffles will be developed.

DD1.4.3 Selection of appropriate microwave **absorbing material** at around 10GHz; design of the interior baffles around the Gaussian beam, and a “tunnel” between the two reflectors and the receivers (Landy, *et al.*, 2008, Baker, Stephenson and Li, 2008). A computer program for ray and wave-front tracing of the PPF and the BFF will be developed and utilized for the internal curvature of the detector enclosure and baffle design. An analysis will be made of the latest technology reported by Chan *et al.* (2006), Landy *et al.* (2008), and Yang *et al.* (2008), and these will be compared with those available from established suppliers of current technology high-performance microwave absorbing materials including ARC Technologies, Inc. (San Diego, California), Millimeter Wave Technology Inc. (Passaic, New Jersey), Cuming Microwave (Avon, Massachusetts), ETS Lindgren Rantec Microwave Absorbers and many others.

DD1.5 Detection Receivers

Design of the microwave receivers (for the PPF) at each end of the detector containment vessel, tunable around 10GHz: **G.V. Stephenson (TSC), Dr. R.C. Woods (LSU) + graduate student**. Three possibilities have already been identified for the technology to be used here, and specifications will be developed for each option found suitable for use in the final design so as to enable a final choice to be made. Layout and specifications (ready for procurement and construction) activity by draftsmen and technical editor(s) (**GravWave® LLC**).

DD1.5.1 Off-the-shelf microwave horn plus HEMT receiver: if tens to hundreds of photons per sample are available then standard microwave horns may be used, coupled to high electron mobility transistor (HEMT) amplifiers. This task will include a sensitivity analysis of this receiver type to determine the suitability of this approach, and a conceptual design will be developed using off-the-shelf components. Now highly developed, HEMT technology has previously been found reliable enough to use in the receivers for differential microwave radiometers (DMRs) flown in the NASA COsmic Background Explorer (COBE) satellite mission.

DD1.5.2 Rydberg-Cavity Receiver as developed at Kyoto University (Yamamoto *et al.*, 2000): Rydberg atoms are excited atoms with one or more electrons that have a much higher principal quantum number than ground state, usually conditioned *via* laser pumping. The low binding energy of the excited electrons leads to very low photoionization energy; therefore, Rydberg atoms are sensitive to low-energy microwave photons, and allow a microwave device somewhat analogous to a conventional photomultiplier tube to be constructed. When a microwave photon strikes a high cross-section Rydberg atom, it causes the electron to be ejected and the atom is ionized. If a large electric field is established within the container, the electron is accelerated, causing cascading impact ionization. The advantage of this receiver is that it is sensitive to low-energy single-photon events, and has very good time resolution. The disadvantage is its cost and complexity. This task will include a conceptual design of an alternative Rydberg atom receiver apparatus suitable for the PPF arising from HFRGW, and will also include a sensitivity calculation of the proposed apparatus.

DD1.5.3 Circuit QED microwave receiver as developed at Yale University (Schuster *et al.*, 2007): a third option will also be explored, the Circuit QED microwave photon receiver. A resonant co-planar waveguide, containing a Cooper Pair Box (CPB) in the center and delineated by Josephson junctions, define a photo-sensitive area in the center of the cavity. The cavity qubit energy levels shift when the cavity encounters a microwave photon. The advantage of this type of receiver is that it is very sensitive to individual photons and can integrate multiple photons over time. It has the disadvantage that this device is of a unique design that is currently available only from Yale University, and is likely not to be exportable. This task will include developing a conceptual design using this alternative type of receiver for the PPF arising from HFRGW.

DD1.6 Cryogenic System

Specification and design of the cryogenic system refrigeration unit, required for low-temperature operation to obtain the best possible reduction in intrinsic thermal noise: **R.C. Woods (LSU) + graduate student, R. M L Baker (TSC) and C. S. Black (GravWave® LLC)**. The required criterion is that the temperature T satisfies $k_B T \ll \hbar \omega$ (where k_B is Boltzmann's constant), i.e. $T \ll \hbar \omega / k_B \approx 480\text{mK}$ for detection at 10GHz. This condition is satisfied by the target temperature for the interaction volume $T < 48\text{mK}$, which can be obtained using a common helium-dilution refrigerator. Then, the signal PPF will be significantly greater than the thermal photon flux. Cost/performance tradeoffs may also be important in this design, so that other possible economic solutions to receiver cooling will also be considered before finalizing the design.

DD1.6.1 Off-the-shelf cryogenic systems: a number of companies have developed ultra-low temperature systems (mK range) for a variety of applications. A common application is refrigeration of receivers as needed in the Li-Baker HFRGW detector. One possibility is the Oxford Instruments' Kelvinox MX range (see summary data attached) that appears to suit the present requirements subject to further evaluation of each model in the range. Other manufacturers to be investigated include Scientific Magnetics (UK), and Cryofab Inc. (Kenilworth, New Jersey).

DD1.6.2 Specifications for system best suited to the detector: specifications will be established for the selected cryogenic system. This will include cryogen level monitoring devices (e.g., Oxford Instruments Intelligent Level Meter ILM200) for warning if the cooling fails.

DD1.7 Electromagnet

Development of the electromagnet specification needed to produce the required static magnetic field (up to 35T, ~3T nominal): **Dr. R.C. Woods (LSU) + graduate student, Dr. R. M L Baker (TSC) and C. S. Black (GravWave® LLC), G.V. Stephenson (GravWave® LLC).** It is expected that a commercial design can be identified for this task. The chosen design will be capable of providing the requisite magnetic field at least over the interaction cavity volume in the containment vessel. Exceptional field-uniformity is not a particularly important issue in this application, though the GW interaction volume or cavity (roughly cylindrical, 9cm diameter and 30cm long) plus extra volume for the surrounding apparatus is somewhat larger than many other experimental applications require, and the required field is perpendicular to the cylindrical axis. Hence, one solution is that the final solenoid design must completely surround the cylindrical axis of the interaction volume perpendicular to the applied field. An alternative approach is to use two or more solenoids, one each side of the interaction volume, similar to the popular Helmholtz coil configuration. In a development of this, a number of small (~9cm diameter) solenoids could be stacked along the length of the interaction volume, with their Helmholtz-like opposite paired solenoids the other side of the interaction volume. In the latter cases, since the paired solenoids are not perfect ring coils, the resultant field would be non-uniform. A quantitative estimate would be needed to ensure that the non-uniformity is not serious in the present application, but this is not expected to be a problem since field non-uniformity just produces non-uniform PPF generation in the interaction volume. Any non-parallelism of the magnetic field or widening of the field of view can be accomplished by introducing an array of microwave receivers in planes parallel to the y-z plane (of Fig. 1) at the ± 100 cm points on the x axis. The two semi-paraboloidal reflectors would still focus all the PPF at the receivers. The design tradeoff will be whether one or two large magnets are more cost-effective than a larger number of smaller magnets. The design effort will be divided into two major sub-tasks: off-the-shelf electromagnets currently available, and emerging-technology proposed magnets that may become available during the construction phase of the HFRGW detector. Each subtask will include a detailed (ready for procurement and construction) plans and specifications activity by draftsmen and technical editor(s) (**GravWave® LLC**).

DD1.7.1 Off-the-shelf hardware: Excepting major installations, iron-core magnets are limited to around 2T over small volumes so that superconducting magnets are expected to be used here. Cryogen-free (more accurately, the cryogen is completely enclosed and recycled each time the magnet is cooled for use) superconducting magnets producing fields up to 16T are available commercially from a number of manufacturers including Scientific Magnetics, Oxford Instruments, and Cryogenic Ltd. (all UK). As examples, Oxford Instruments can supply magnets producing 16T in a 10cm bore, and 5T in a 1m bore. Typically, cooling is provided by an integral Gifford-McMahon cryo-cooler at 4.2K. Use of a cryogen-free “dry” magnet means that there are no cold seals to be a source of leaks.

DD1.7.2 Emerging technology: Since the detection PPF signal is directly proportional to the static magnetic field value, the detector sensitivity will be increased by using larger fields than currently-available commercial designs permit. To this end we will investigate

the feasibility of co-developing with a third-party (e.g., National High Magnetic Field Laboratory, Tallahassee, Florida) a custom-made high-field design capable of up to 35T (Bird, 2004), which may be realizable during the construction phase of the Li-Baker detector. If successful, achieving this value of magnetic field would improve the sensitivity of the Li-Baker detector by an order of magnitude. In this case, if a separate refrigeration system is required, the specification would include cryogen level-monitoring to ensure safe auto-rundown of the superconducting magnet if the helium level falls below a pre-set value, to reduce the danger associated with cryogenic-system related magnet failure.

Systems Engineering Tasks

Following the completion of the Li-Baker detector development tasks, plans and specifications will be drawn up by **TSC** in collaboration with **GravWave® LLC** and **LSU**. **TSC**, **LSU** and **GravWave® LLC** are fully capable of completing the entire project on their own; however, an effort coordinated with the ongoing HFGW research program at *Chongqing University* (China) will have mutual synergetic value and will greatly enhance the outcome of the present project. Since overlap of tasks is possible, approximately 18 months will be allowed for the detector design, and approximately 8 months for the preparation of plans and specifications. With approximately two months overlap of the major tasks; a total of two years will be scheduled for the detector's design and development of the plans and specifications. Fig. 3 shows a Gannt chart for scheduling the project.

For any large engineering project, coordination among investigators is important for the development of a coherent, unified design. This is the role of systems engineering tasks, depicted at the top of Fig. 3. In the present case, the development of the detector will demand the close coordination of the detection link budget very early on, in order to carefully guide the component design for each of the component areas, and to ensure that the sensitivity goals can be met. This task culminates in a review of the predicted signal-to-noise ratio.

Follow-on to this task is the development of key component requirements responsive to the design aspects important to maintaining a coherent, self-consistent design, ending in a requirements review corresponding to the preliminary design review of component equipment areas. Interface requirements development is the next level of detail in systems engineering task area, resulting in interface control documentation/drawing review prior to the critical design reviews of the component equipment areas. Finally, the systems engineering activity concludes with the development of test plans that will detail integration activities and reduce integration risk in subsequent phases. These activities are standard level-of-effort tasks that are rolled into other task bids as a background activity.

4. Gantt Chart

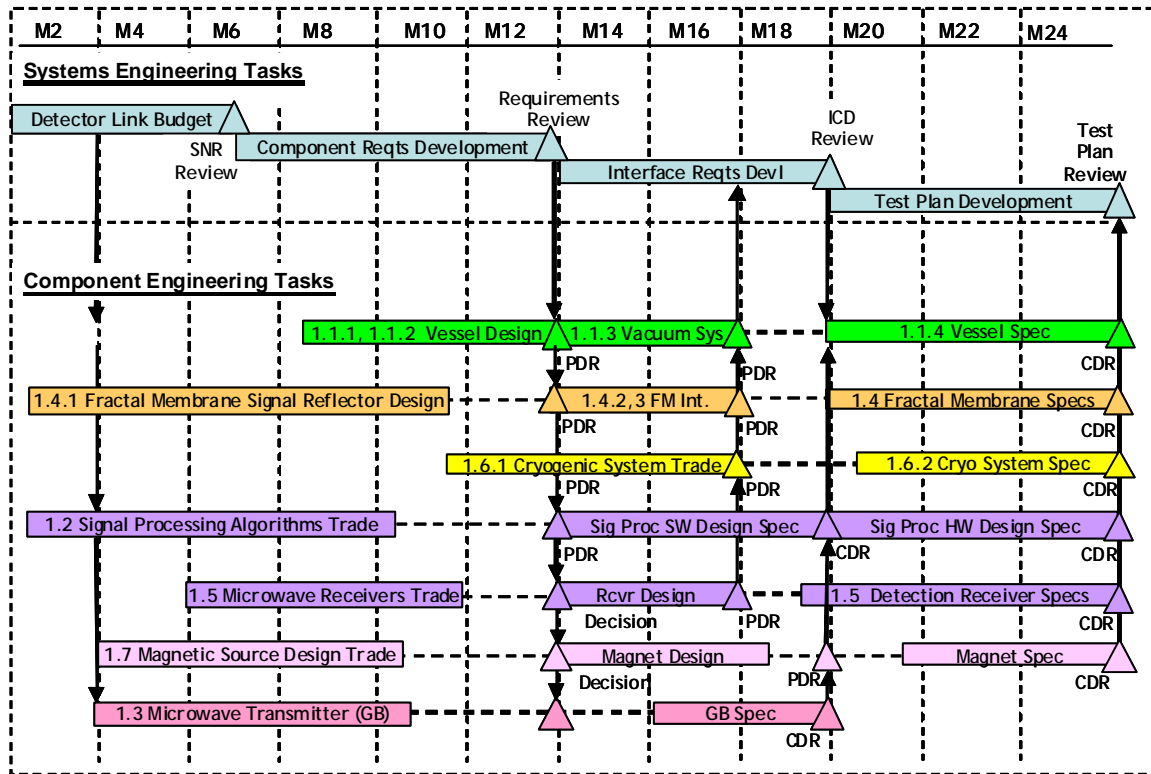

ICD = Interface Control Drawing
PDR = Preliminary Design Review = design approval
CDR = Critical Design Review = design complete

Fig. 3: Project Design Plans, and Specifications Development Schedule, for Relic HFGW Detection System

5. Prior related work by collaborators

(i) Baker, Woods and Stephenson participated in both the First and the Second International HFGW Workshops and along with Black presented papers SPESIF 2009 HFGW Symposium sponsored by SPESIF.

The first *High-Frequency Gravitational Wave Conference* (International High-Frequency Gravitational Wave Working Group) was held in May 2003 at the MITRE Corporation in McLean, Virginia. The Conference was dedicated to Robert Lull Forward who coined the term *High-Frequency Gravitational Waves*. The meeting attracted over 50 scientists from 14 countries and 25 technical papers were presented. Several HFGW research pioneers were present including Leonid P. Grishchuk from Russia and the UK, Valentin N. Rudenko from Russia, Giorgio Fontana from Italy, Eric W. Davis, Senior Scientist at the Institute for Advanced Studies at Austin, Texas, **Gary V. Stephenson** of Boeing, El Segundo, California, and **R. Clive Woods**, then a Professor in the Department of Electrical and Computer Engineering, Iowa State University and papers by Fangyu Li of Chongqing University, China. **Robert M L Baker, Jr.** of **GravWave® LLC** and **TSC** and Paul Murad of the US Department of Defense (Washington, D.C.) were co-chairmen of the Conference.

Relic and other HFGWs were the subjects discussed at the *Second International HFGW Workshop* (<http://earthtech.org/hfgw2/>) held at the Institute for Advanced Studies at Austin, Texas, in September 2007. Scientists from the United States, China, Russia and Italy presented

and discussed their HFGW research. Presentations included Ultra-High Sensitivity HFGW detectors (with sensitivities that might reach HFGW amplitudes as small as 10^{-37}), means of generating HFGWs in the laboratory using long arrays of piezoelectric crystals (building upon the earlier work of Romero and Dehnen (1981) presented at the first HFGW Conference and based upon rigorous general relativistic analyses) using off-the-shelf components and producing HFGW amplitudes ranging from 10^{-32} to 10^{-24} , and studies by Rudenko and Grishchuk that proved the existence of HFGW relic gravitational radiation. **Robert M L Baker, Jr.** of **GravWave® LLC** and **TSC** was Honorary Chairman of the Workshop.

(ii) The Principal Investigator or **PI, Robert M L Baker, Jr.** filed the first Patent application (now granted) for a GW generator in 1999 (Baker, 1999). Dr. Baker was also awarded subsequent US patents for a GW generator (Baker, 2000), and holds the Chinese patent for the Li-Baker HFGW detector (Baker, 2001). The present company, **GravWave® LLC**, holds 6 Patents and 14 Pending Patents in the Peoples' Republic of China and the United States for High-Frequency Gravitational Wave technology.

(iii) Project Scientist, **R. Clive Woods, LSU**, has made many contributions published in peer-reviewed research journals and international conferences in the fields of gravitational interactions and high-frequency gravitational waves, in addition to being closely involved in the development of the "Lucky Drift" model of impact ionization (of relevance to the Rydberg-cavity receiver option here). He has also made many other contributions in fields as diverse as microelectronic devices, photonics, superconducting antennas, acoustics, high-speed signal processing, project assessment, magnetic resonance, and others.

(iv) Project Scientist, **Gary V. Stephenson** has published a number of papers in peer reviewed research journals on gravitational waves and the Gertsenshtein effect. He has also made a number of contributions in the area of large-scale aerospace systems, including strategic infrared surveillance and tracking design, space-borne meteorological sensor instrumentation design, microwave detection, and geo-location system design, and the design of distributed sat-com systems.

(v) Project Scientist, **Christine S. Black** presented a paper concerning HFGWs at the HFGW Workshop in Huntsville, Alabama in 2009 and has worked part time for GravWave® LLC since 2007.

6. General Work Assignments

(i) The work proposed here is to be performed by **TSC** with subcontractors **GravWave® LLC**, which owns the patents for the Li-Baker HFGW Detector, and **LSU**. The Principal Investigator or **PI, Dr. Robert M L Baker, Jr.**, (see biographical sketch) will have overall responsibility for the project, including project management and design activity and will provide science oversight and systems engineering services on the project.

(ii) The major tasks will be undertaken on a fee basis by **TSC** and subcontractor **GravWave®** under the supervision of the **PI, Robert M L Baker, Jr.** The **PI** has worked extensively with Dr. Woods commencing in 2003, while Dr. Woods was at Iowa State University, and continuing from 2006 when Professor **R. Clive Woods** relocated to Louisiana State University, and this work has resulted in many peer-reviewed scientific papers (see biographical sketch). From 2004 the **PI** has worked extensively with **Gary V. Stephenson** including coauthoring several HFGW papers. Since 2007 the **PI** has utilized the services of Project Scientist **Christine S. Black** during the summer in various HFGW research projects (see biographical sketch) under the auspices of GravWave® LLC.

(iii) Also contributing to the **TSC** component of the work is Project Scientist **Gary V. Stephenson** (see biographical sketch), who has also worked extensively on gravitational wave research with Dr. Baker since 2004 and will be leading task DD1.5, the development of a microwave detection system, and will be assisting with a number of other tasks including DD1.2, signal processing, and DD1.7, HTSC Electromagnet development.

(iv) The bulk of the technical work allocated to **LSU** is to be performed by a graduate student or students, as a direct major educational benefit counting towards the award of a graduate degree. Professor **R. Clive Woods** will supervise the graduate student or students appointed to this program as thesis advisor and major professor.

(v) The conversion of the top-level detector designs to definitive plans and specifications will be assisted by a graduate student or graduate students and technical staff at **LSU**. The major effort here will, however, be accomplished by draftsmen and technical editor(s) of **GravWave® LLC**.

(vi) **TSC** was organized as a California Corporation in 1967 and was awarded **Office of Naval Research** contracts (N00014-76-C-0904, 1977 and N6601-78-C-0375, 1978). Since 1998, **TSC** and **GravWave® LLC** have supported **Robert M L Baker, Jr.**, in his research into the **laboratory generation, detection and practical applications of HFGWs**. To date this support has resulted in the publication of **28 peer-reviewed scientific articles relating to HFGWs** and his **attendance at eleven prestigious scientific research conferences**.

(vii) The results of the research will be disseminated to the world-wide scientific community by publication in **international peer-reviewed research journals** and prestigious research conferences, by using the world-wide-web, and by discussion with interested colleagues at research conferences and also informal meetings.

(viii) The present statement of work will pave the way for a future statement of work to commence construction of the Li-Baker HFGW Detector described herein. Successful construction of this detector will have a wide-ranging impact on the emergent fields of **primordial relic HFGW, HFGW engineering, applications of HFGW such as telecommunications, HFGW optics, and quantum interactions between HFGW and electromagnetism**.

7. Level of Effort

Component Task	First Year									
	Design (Hours)				Plans & Specifications (Hours)					
	RB	CW	GS	CB	RB	CW	GS	CB	D&TE	
1.1 Containment Vessel	10	5	30	40	0	0	5	10	120	
1.2 Signal Processing	80	0	100	80	10	0	20	40	60	
1.3 Microwave Transmitter	50	20	100	0	5	5	5	0	20	
1.4 Reflector Array	120	0	0	80	20	0	0	40	80	
1.5 Microwave Receivers	0	12	120	0	0	0	20	20	40	
1.6 Cryogenic System	40	20	0	20	10	0	0	10	10	
1.7 Electromagnet	40	120	0	40	0	20	0	8	40	
Reports & Coordination	40	10	10	20	0	0	0	0	80	
Totals	380	187	360	280	35	25	25	78	270	

RB = Robert Baker (TSC)
CW = Clive Woods (LSU)
GS = Gary Stephenson (TSC)
CB = Christine Black (GravWave® LLC)
D&TE = Draftsman and Technical Editor (GravWave® LLC)

Component Task	Second Year									
	Design (Hours)				Plans & Specifications (Hours)					
	RB	CW	GS	CB	RB	CW	GS	CB	D&TE	
1.1 Containment Vessel	4	0	0	0	20	8	20	40	120	
1.2 Signal Processing	4	0	20	0	20	8	40	0	40	
1.3 Microwave Transmitter	24	8	50	0	5	5	5	10	40	
1.4 Reflector Array	40	0	0	20	40	0	0	40	80	
1.5 Microwave Receivers	0	12	60	0	0	0	80	20	40	
1.6 Cryogenic System	40	20	0	20	40	40	0	10	10	
1.7 Electromagnet	40	120	0	40	0	20	0	8	80	
Reports & Coordination	40	10	10	20	0	0	0	0	80	
Totals	192	170	140	100	125	81	145	128	490	

RB = Robert Baker (TSC)
CW = Clive Woods (LSU)
GS = Gary Stephenson (TSC)
CB = Christine Black (GravWave® LLC)
D&TE = Draftsman and Technical Editor (GravWave® LLC)

Biographies

Robert M L Baker, Jr.

Principal Investigator (PI) and Project Manager

Robert M L Baker Jr., was born in Los Angeles on September 1, 1930. He has been married to his wife Bonnie since 1964 and has three grown children. Baker earned a bachelor's degree in Physics at UCLA with highest honors (*summa cum laude* – first in his class) was elected to *Phi Beta Kappa*, earned a master's degree in Physics and a Ph.D. in Engineering at UCLA—the Ph.D. degree with a specialization in space navigation was, according to UCLA officials, the first of its kind to be granted in the United States. Dr. Baker was on the faculty of the Department of Astronomy at UCLA from 1959 to 1963 and the Department of Engineering and Applied Science at UCLA from 1963 to 1971 as a Lecturer and Assistant Professor. During that time he was a Lecturer at the *United States Air Force Academy*. While on a two-year tour of active duty in the Air Force he worked on a variety of classified aerospace projects. He was the head of the Lockheed's *Aerodynamics Research Center* in Bel Air, California and in 1964 joined *Computer Sciences Corporation* as the Associate Manager for Mathematical Analysis. In 1980 he was elected President of *West Coast University*, an accredited university for the adult learner (Western Association of Schools and Colleges or WASC and Accreditation Board for Engineering and Technology or ABET) now operating under the auspices of *American Career College* in Los Angeles. After retiring from West Coast University in 1997 as President and Professor of Engineering, Dr. Baker became the Senior Consultant for *Transportation Sciences Corporation* and *GRAVWAVE© LLC*. He won the *UCLA Physics Prize*, was recipient of the *Dirk Brouwer Award* for outstanding contributions in astrodynamics and orbital mechanics, and was a recipient of the *Outstanding Man of the Year Junior Chamber of Commerce* award in 1965 presented to him by Ronald Reagan. He is a *fellow* of the *American Association for the Advancement of Science*. He was national chairman of the Astrodynamics Technical Committee of the *American Institute of Aeronautics and Astronautics (AIAA)* from 1961 to 1964, was Editor of the *Journal of the Astronautical Sciences* from 1963 to 1975, was appointed by William Bennett to the *National Advisory Committee on Accreditation and Institutional Eligibility* of the Department of Education from 1987 to 1989, was appointed to the *Academic Review Committee on Gravitational Research* with the U. S. Army from 2001 to 2003, Head of Committee on High-Frequency Gravitational Waves of the *Oakland Institute for Gravitational Wave Research 2002-*, Vice Chairperson of the first International HFGW Workshop at the MITRE Corporation in 2003, Honorary Chairman of the second International HFGW Workshop in Austin Texas in 2007, Chairman of the third International HFGW Workshop in Huntsville, Alabama in 2009, Advisory Professor *Chongqing University*, China 2004, and was the author of several textbooks and over one hundred company reports, symposium papers, and journal articles in the area of astrodynamics, celestial mechanics, and High-Frequency Gravitational Waves (HFGWs) including *An Introduction to Astrodynamics* (1960) with Maud W. Makemson and *Astrodynamics: Applications and Advanced Topics* (1969). Dr. Baker has been Project Manager and Principal Investigator (**PI**) on three prototype development, fabrication, and test projects under contract to the U. S. Navy and Principal Investigator on several NASA and USAF projects while head of Lockheed's *Aerodynamic Research Center*. As President of *West Coast University* Dr. Baker coordinated the activities of six groups of scientists and engineers spread throughout Southern California. Dr. Baker has been interested in the dynamics of gravitational fields since the 1950's and gravitational-wave research since the early 1960's. He holds six patents and 14 pending patents in the United States, Europe, Russia, and China in the area of gravitational-wave generation and detection in the laboratory. You are invited to visit: www.DrRobertBaker.com.

R. Clive Woods

Project Scientist

R. Clive Woods was born in Leicester, England on May 18, 1955. Currently he is Department Chairman and Voorhies Distinguished Professor, Department of Electrical and Computer Engineering, *Louisiana State University*. Woods earned a Master's degree and Doctorate at New College, *University of Oxford*, 1976 and 1980, for work on magnetic resonance in rare earth metal alloys in the Solid State Physics group of the Clarendon Laboratory in the *University of Oxford*. Dr. Woods was a Senior Scientist and Project Manager at Plessey Research (Caswell) Ltd. from 1982 to 1983, and Lecturer and Senior Lecturer on the faculty of the Electronic and Electrical Engineering Department of the *University of Sheffield* from 1983 to 2001. During this period he managed projects on the design, development, and test of microwave acoustic devices, III-V heterojunction bipolar transistors, avalanche photodiodes, high-temperature superconductors, and other solid-state devices. In 1989 he was appointed as a *British Association Media Fellow* and in 1995 he was Professeur Invité at the Laboratoire de Physique de la Matière, *Institut National des Science Appliquées* de Lyon, France. From January 2002 to June 2006 Dr. Woods was a Full Professor of Electrical and Computer Engineering at *Iowa State University*, Ames, Iowa. During 1992-1995 he was a Member of IEE Professional Group Committee S8 (Electromagnetics); 1999-2002 a Member of IEE Professional Group Committee E3 (Microelectronics and Superconductor Devices); 1999-2002 an Associate Editor of *IEE Electronics and Communication Journal*, and in 2003 a Member of the *National Science Foundation SBIR/STTR Photonics (Lasers and LEDs)* panel. Dr. Woods has consulted for Barnsley Business and Innovation Centre Ltd., McLaren's Ltd., Price Waterhouse, John Lovell Associates, Halpern & Ward Associates, the European Commission in Brussels, and Ashton Brown Associates Ltd. among others. He has authored over 70 technical papers and the book "Digital logic design" (with B. Holdsworth), Butterworth-Heinemann, 2002. Dr. Woods has been interested in the research associated with gravitational-waves for over a decade and participated in the first International HFGW Workshop at the MITRE Corporation in 2003, the second International HFGW Workshop at Austin, Texas in 2007 and the third at Huntsville, Alabama in 2009. <http://myprofile.cos.com/cwoods>

Gary V. Stephenson

Project Scientist

Gary Stephenson received his B. S. Degree in Physics at Montana State University in 1983 and from 1984 to 2000 performed graduate studies at the University of California, Purdue University and the University of Washington in Physics and Electrical Engineering. From 1983 to 1986 he was a Member of the Technical Staff at Hughes Aircraft Company where as a systems engineer he worked on optical and radar systems. In 1986 Mr. Stephenson joined the Aerospace Optical Division of ITT where he performed research, development, and systems design studies of space borne meteorological Infrared imagers. In 1989 through 1997 he returned to Hughes as a Systems Engineer where he was responsible for the electro-optical systems engineering and on-site support of AST, an airborne infrared tracking sensor for the U. S. Army, and prepared a number of statement of works, including technical volumes for early phases of EAGLE (Extended Airborne Global Launch Evaluator), mobile THEL (Tactical High Energy Laser), and NPOESS (National Polar-orbiting Operational Environmental Satellite System). From 1997 to the current date he has been a Systems Engineer at The Boeing Company where he has again been involved in the systems design of electromagnetic and electro-optical mission equipment, including TAPLOC, (TENCAP AWACS Precision Location) and Connexion by Boeing. Stephenson is an expert on the Gertsenshtein effect (utilized for both generation and detection of HFGWs) and has published several papers in that area. Since 1997 he has also been the president and chief investigator for Seculine Consulting. Mr. Stephenson has publications in a variety of applications areas, seven patents, participated in the first International HFGW Workshop at the MITRE Corporation in

2003, the second International HFGW Workshop at Austin, Texas in 2007, and cochairman of the third at Huntsville, Alabama in 2009. He has publications in the communications applications of high-frequency gravitational waves.

Christine S. Black

Project Scientist

Christine Black graduated from *The University of Michigan* in 2009 majoring in Astronomy and Astrophysics with an interdisciplinary major in Physics. She has taken courses in EM Theory, Quantum Mechanics, Celestial Mechanics (Stars and Galaxies), Optics, Special Relativity and Astronomical Techniques with a GPA of 3.0. She is also currently doing research with a professor at the University involving variable stars in the nearby galaxy Carina and will accomplish post graduate research at the University of Tasmania. She has a keen interest in HFGW research and has been an assistant of Dr. Robert M L Baker, Jr. as a Project Scientist at GravWave® LLC since 2007 and presented a paper with him at the third HFGW Workshop in February, 2009 at Huntsville, Alabama..

Institution Snapshots

About Transportation Sciences Corporation (TSC)

Transportation Sciences Corporation, or TSC, is a company dedicated to the research, development, and manufacture of products involving the generation, detection, and application of High-Frequency Gravitational Waves (HFGWs) in the United States. It is a California Corporation founded in 1967 and based in Playa del Ray, California. It is a National Science Foundation *FastLane* participant (NSF ID 000512905, TSC ID 6250016969). Its EIN/TIN number is 952502248 and DUNS Number is 783491590. TSC has received U S Navy contracts in the area of submarine surveillance and unmanned hydrophone-array tender design, prototype construction and test and hydrofoil sail craft design and is now involved in efforts to create important practical, commercial and military high-technology applications for HFGWs, including communication (GravCom®), propulsion, remote force generation, imaging, energy generation, radioactive-waste-free nuclear-energy generation, astronomy, and applied physics in the United States. The Corporation's mission is accomplished through rigorous research and experiments reported in peer-reviewed scientific journals. These efforts will lead to the development, manufacture, production, and sale of nano-, micro-, and macro-scale HFGW devices and equipments, many intended to improve the quality of life.

About GravWave LLC

GravWave® LLC is a company dedicated to the research, development, and manufacture of products involving the generation, detection, and application of High-Frequency Gravitational Waves (HFGWs) utilizing patented, proprietary technology. Founded in 2000 and based in Playa del Ray, California, it is the first company to pioneer efforts to create important practical, commercial and military high-technology applications for HFGWs, including communication, propulsion, remote force generation, imaging, energy generation, radioactive-waste-free nuclear-energy generation, astronomy, and applied physics. The corporation's mission is accomplished through rigorous research and experiments reported in peer-reviewed scientific journals. These efforts will lead to the development, manufacture, production, and sale of nano-, micro-, and macro-scale HFGW devices and equipments, many intended to improve the quality of life.

About Louisianan State University (LSU)

Louisianan State University is heavily involved in the development of the low-frequency GW detector LIGO. As such there is opportunity for some intellectual overlap, though this is actually quite limited because as explained elsewhere the LIGO technology is completely different from the detection method and noise suppression proposed here. (An analogy is that microwave engineers do not generally work closely with extra-low-frequency and audio engineers because the technologies and methodologies are too widely divergent.) Nevertheless, any opportunities for collaboration will be taken if any present themselves. Many of the lessons learned in the course of development of LIGO may be applicable to the present HFGW detector design, including (in particular) issues surrounding noise reduction (Stephenson, 2009).